Instruction Manual

PUMP Application Inverter

IMO Jaguar VXA

⚠ CAUTION

Thank you for purchasing our Jaguar VXA series of inverters.

- This product is designed to drive a three-phase induction motor. Read through this instruction manual and be familiar with the handling procedure for correct use.
- Improper handling might result in incorrect operation, a short life, or even a failure of this product as well as the motor.
- Deliver this manual to the end user of this product. Keep this manual in a safe place until this product is discarded.
- For how to use an optional device, refer to the instruction and installation manuals for that optional device.

Copyright © 2013 IMO Precision Controls Ltd

All rights reserved.

No part of this publication may be reproduced or copied without prior written permission from IMO Precision Controls Ltd.

All products and company names mentioned in this manual are trademarks or registered trademarks of their respective holders.

The information contained herein is subject to change without prior notice for improvement.

Preface

Thank you for purchasing our JAGUAR VXA series of inverters. This product is designed to drive a three-phase induction motor. This instruction manual provides only minimum requisite information for wiring and operation of the product. Read through this manual before use.

For details about this product, refer to the JAGUAR VXA User's Manual that contains the precautions, detailed functions and specifications, wiring, configuration and maintenance.

Related documentation

- JAGUAR VXA User's Manual

These materials are subject to change without notice. Be sure to obtain the latest editions for use.



We plan to make the latest edition of the User's Manual available for download from the following URL:

www.imopc.com

■ Safety precautions

Read this manual thoroughly before proceeding with installation, connections (wiring), operation, or maintenance and inspection. Ensure you have sound knowledge of the device and familiarize yourself with all safety information and precautions before proceeding to operate the inverter.

Safety precautions are classified into the following two categories in this manual.

 WARNING	Failure to heed the information indicated by this symbol may lead to dangerous conditions, possibly resulting in death or serious bodily injuries.
 CAUTION	Failure to heed the information indicated by this symbol may lead to dangerous conditions, possibly resulting in minor or light bodily injuries and/or substantial property damage.

Failure to heed the information contained under the CAUTION title can also result in serious consequences. These safety precautions are of utmost importance and must be observed at all times.

Application

 WARNING
<ul style="list-style-type: none">• This product is designed to drive a three-phase induction motor. Do not use it for single-phase motors or for other purposes. Fire or an accident could occur.• This product may not be used for a life-support system or other purposes directly related to the human safety.• Though the product is manufactured under strict quality control, install safety devices for applications where serious accidents or property damages are foreseen in relation to the failure of it. An accident could occur.

Installation

 WARNING
<ul style="list-style-type: none">• Install the inverter on a base made of metal or other non-flammable material. Otherwise, a fire could occur.• Do not place flammable object nearby. Doing so could cause fire.

CAUTION

- Do not support the inverter by its front cover during transportation.
Doing so could cause a dropping of the inverter and lead to possible injury.
- Prevent lint, paper fibers, sawdust, dust, metallic chips, or other foreign materials from getting into the inverter or from accumulating on the heat sink.
- When changing the positions of the top and bottom mounting bases, use only the specified screws.
Otherwise, a fire or an accident might result.
- Do not install or operate an inverter that is damaged or lacking parts.
Doing so could cause fire, an accident or injuries.

Wiring

WARNING

- If no zero-phase current (earth leakage current) detective device such as a ground-fault relay is installed in the upstream power supply line in order to avoid the entire power supply system's shutdown undesirable to factory operation, install a residual-current-operated protective device (RCD)/earth leakage circuit breaker (ELCB) individually to inverters to break the individual inverter power supply lines only.
Otherwise, a fire could occur.
- When wiring the inverter to the power source, insert a recommended molded case circuit breaker (MCCB) or residual-current-operated protective device (RCD)/earth leakage circuit breaker (ELCB) (with overcurrent protection) in the path of each pair of power lines to inverters. Use the recommended devices within the recommended current capacity.
- Use wires in the specified size.
- Tighten terminals with specified torque.
Otherwise, a fire could occur.
- When there is more than one combination of an inverter and motor, do not use a multicore cable for the purpose of handling their wirings together.
- Do not connect a surge killer to the inverter's output (secondary) circuit.
Doing so could cause a fire.
- Be sure to ground the inverter's grounding terminals G.
Otherwise, an electric shock or a fire could occur.
- Qualified electricians should carry out wiring.
- Be sure to perform wiring after turning the power OFF.
Otherwise, an electric shock could occur.
- Be sure to perform wiring after installing the inverter unit.
Otherwise, an electric shock or injuries could occur.
- Ensure that the number of input phases and the rated voltage of the product match the number of phases and the voltage of the AC power supply to which the product is to be connected.
- When using this product in combination with a PWM converter, refer to the instructions given in the JAGUAR VXA User's Manual.
Otherwise, a fire or an accident could occur.
- Do not connect the power supply wires to the inverter output terminals (U, V, and W).
Doing so could cause fire or an accident.

WARNING

- In general, sheaths of the control signal wires are not specifically designed to withstand a high voltage (i.e., reinforced insulation is not applied). Therefore, if a control signal wire comes into direct contact with a live conductor of the main circuit, the insulation of the sheath might break down, which would expose the signal wire to a high voltage of the main circuit. Make sure that the control signal wires will not come into contact with live conductors of the main circuit.
Doing so could cause an accident or an electric shock.

WARNING



- Before changing the switches, **turn OFF the power and wait at least 10 minutes**. Make sure that the charging lamp is turned OFF. Further, make sure, using a multimeter or a similar instrument, that the DC link bus voltage between the terminals P(+) and N(-) has dropped to the safe level (+25 VDC or below).
Otherwise, an electric shock could occur.

CAUTION

- The inverter, motor and wiring generate electric noise. Be careful about malfunction of the nearby sensors and devices. To prevent them from malfunctioning, implement noise control measures.
Otherwise an accident could occur.
- The leakage current of the EMC filter built-in type of inverters is comparatively large. Be sure to perform protective grounding.
Otherwise, an accident or an electric shock could occur.

Operation

WARNING

- Be sure to mount the front cover before turning the power ON. Do not remove the cover when the inverter power is ON.
Otherwise, an electric shock could occur.
- Do not operate switches with wet hands.
Doing so could cause electric shock.
- If the auto-reset function has been selected, the inverter may automatically restart and drive the motor depending on the cause of tripping. Design the machinery or equipment so that human safety is ensured at the time of restarting.
Otherwise, an accident could occur.
- If the stall prevention function (current limiter), automatic deceleration (anti-regenerative control), or overload prevention control has been selected, the inverter may operate with acceleration/deceleration or frequency different from the commanded ones. Design the machine so that safety is ensured even in such cases.
- The  key on the keypad is effective only when the keypad operation is enabled with function code F02 (= 0, 2 or 3). When the keypad operation is disabled, prepare an emergency stop switch separately for safe operations.
Switching the run command source from keypad (local) to external equipment (remote) by turning ON the "Enable communications link" command **LE** disables the  key. To enable the  key for an emergency stop, select the STOP key priority with function code H96 (= 1 or 3).
- If any of the protective functions have been activated, first remove the cause. Then, after checking that the all run commands are set to OFF, release the alarm. If the alarm is released while any run commands are set to ON, the inverter may supply the power to the motor, running the motor.
Otherwise, an accident could occur.

WARNING

- If you enable the "Restart mode after momentary power failure" (Function code F14 = 3 to 5), then the inverter automatically restarts running the motor when the power is recovered.
Design the machinery or equipment so that human safety is ensured after restarting.
- If the user configures the function codes wrongly without completely understanding this Instruction Manual and the JAGUAR VXA User's Manual, the motor may rotate with a torque or at a speed not permitted for the machine.
An accident or injuries could occur.
- Even if the inverter has interrupted power to the motor, if the voltage is applied to the main circuit input terminals L1/R, L2/S and L3/T, voltage may be output to inverter output terminals U, V, and W.
- Even if the motor is stopped due to DC braking, voltage is output to inverter output terminals U, V, and W.
An electric shock may occur.
- The inverter can easily accept high-speed operation. When changing the speed setting, carefully check the specifications of motors or equipment beforehand.
Otherwise, injuries could occur.

CAUTION

- Do not touch the heat sink because it becomes very hot.
Doing so could cause burns.
- The DC brake function of the inverter does not provide any holding mechanism.
Injuries could occur.
- Ensure safety before modifying the function code settings.
Run commands (e.g., "Run forward" **FWD**, "Force to run" **FMS**), stop commands (e.g., "Coast to a stop" **BX**), and frequency change commands can be assigned to digital input terminals. Depending upon the assignment states of those terminals, modifying the function code setting may cause a sudden motor start or an abrupt change in speed.
- When the inverter is controlled with the digital input signals, switching run or frequency command sources with the related terminal commands (e.g., **SS1**, **SS2**, **SS4**, **SS8**, **Hz2/Hz1**, **Hz/PID**, **IVS**, **LE** and **FMS**) may cause a sudden motor start or an abrupt change in speed.
- Ensure safety before modifying customizable logic related function code settings (U codes and related function codes) or turning ON the "Cancel customizable logic" terminal command **CLC**. Depending upon the settings, such modification or cancellation of the customizable logic may change the operation sequence to cause a sudden motor start or an unexpected motor operation.
- If any abnormality is found in the inverter or motor, immediately stop it and perform troubleshooting, referring to the JAGUAR VXA User's Manual.
An accident or injuries could occur.

Maintenance and inspection, and parts replacement

WARNING

- Before proceeding to maintenance or inspection, **turn OFF the power and wait at least 10 minutes**. Make sure that the charging lamp is turned OFF. Further, make sure, using a multimeter or a similar instrument, that the DC link bus voltage between the terminals P(+) and N(-) has dropped to the safe level (+25 VDC or below).
Otherwise, an electric shock could occur.
- Maintenance, inspection, and parts replacement should be made only by qualified persons.
- Take off the watch, rings and other metallic objects before starting work.
- Use insulated tools.
Otherwise, an electric shock or injuries could occur.
- Never modify the inverter.
Doing so could cause an electric shock or injuries.

Disposal

CAUTION

- Treat the inverter as an industrial waste when disposing of it.
Otherwise injuries could occur.

GENERAL PRECAUTIONS

Drawings in this manual may be illustrated without covers or safety shields for explanation of detail parts. Restore the covers and shields in the original state and observe the description in the manual before starting operation.

Icons

The following icons are used throughout this manual.



This icon indicates information which, if not heeded, can result in the inverter not operating to full efficiency, as well as information concerning incorrect operations and settings which can result in accidents.



This icon indicates information that can prove handy when performing certain settings or operations.



This icon indicates a reference to more detailed information.

Conformity to the Low Voltage Directive in the EU

If installed according to the guidelines given below, inverters marked with CE are considered as compliant with the Low Voltage Directive 2006/95/EC.

Compliance with European Standards

Adjustable speed electrical power drive systems (PDS).

Part 5-1: Safety requirements. Electrical, thermal and energy. IEC/EN 61800-5-1: 2007

WARNING

1. The ground terminal  should always be connected to the ground. Do not use only a residual-current-operated protective device (RCD)/earth leakage circuit breaker (ELCB)* as the sole method of electric shock protection. Be sure to use ground wires of recommended size listed on page vii.
*With overcurrent protection.
2. To prevent the risk of hazardous accidents that could be caused by damage of the inverter, install the specified fuses in the supply side (primary side) according to the following tables.
 - Breaking capacity: Min. 10 kA
 - Rated voltage: Min. 500 V

⚠ WARNING ⚠

Power supply voltage	Nominal applied motor (kW)	Inverter type	Fuse rating (A)
Three-phase 400 V	0.75	VXA2A5#-4E	4 (IEC/EN 60269-2)
	1.5	VXA4A1#-4E	6 (IEC/EN 60269-2)
	2.2	VXA5A5#-4E	10 (IEC/EN 60269-2)
	4.0	VXA9#-4E	16 (IEC/EN 60269-2)
	5.5	VXA13A5#-4E	20 (IEC/EN 60269-2)
	7.5	VXA18A5#-4E	25 (IEC/EN 60269-2)
	11	VXA24A5#-4E	35 (IEC/EN 60269-2)
	15	VXA32#-4E	50 (IEC/EN 60269-2)
	18.5	VXA39#-4E	63 (IEC/EN 60269-2)
	22	VXA45#-4E	80 (IEC/EN 60269-2)
	30	VXA60#-4E	100 (IEC/EN 60269-2)
	37	VXA75#-4E	125 (IEC/EN 60269-2)
	45	VXA91#-4E	250 (IEC60269-4)
	55	VXA112#-4E	
	75	VXA150#-4E	350 (IEC60269-4)
	90	VXA176#-4E	
	110	VXA210S-4E	400 (IEC60269-4)
	132	VXA253S-4E	
	160	VXA304S-4E	450 (IEC60269-4)
	200	VXA377S-4E	500 (IEC60269-4)
	220	VXA415S-4E	550 (IEC60269-4)
	280	VXA520S-4E	630 (IEC60269-4)
	315	VXA585S-4E	900 (IEC60269-4)
	355	VXA650S-4E	
400	VXA740S-4E		
500	VXA960S-4E	1250 (IEC60269-4)	
630	VXA1170S-4E	2000 (IEC60269-4)	
710	VXA1370S-4E		

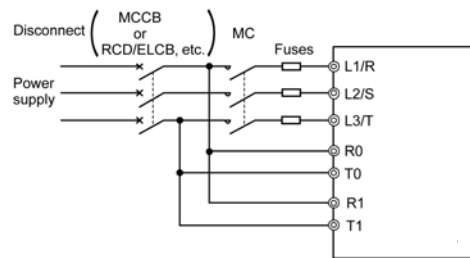

Note: # Enclosure: M (IP21) or L (IP55).

- When used with the inverter, a molded case circuit breaker (MCCB), residual-current-operated protective device (RCD)/earth leakage circuit breaker (ELCB) or magnetic contactor (MC) should conform to the EN or IEC standards.
- When you use a residual-current-operated protective device (RCD)/earth leakage circuit breaker (ELCB) for protection from electric shock in direct or indirect contact power lines or nodes, be sure to install **type B of RCD/ELCB** on the input (primary) of the inverter.
- The inverter should be used in an environment that does not exceed Pollution Degree 2 requirements.
- Install the inverter, AC reactor (ACR), input or output filter in an enclosure with minimum degree of protection of IP2X (Top surface of enclosure shall be minimum IP4X when it can be easily accessed), to prevent human body from touching directly to live parts of these equipment.
Note: Does not apply to IP55 model.
- Do not connect any copper wire directly to grounding terminals. Use crimp terminals with tin or equivalent plating to connect them.
- When you use an inverter at an altitude of more than 2000 m, you should apply basic insulation for the control circuits of the inverter. The inverter cannot be used at altitudes of more than 3000 m.

Conformity to the Low Voltage Directive in the EU (Continued)



9. Use wires listed in IEC 60364-5-52.

Power supply voltage	Nominal applied motor (kW)	Inverter type	MCCB or RCD/ELCB *1 Rated current (A)	Recommended wire size (mm ²)									
				Main terminal				Control circuit	Aux. control power supply [R0, T0]	Sub main circuit power supply R1, T1			
				Main power input		Inverter outputs [U, V, W] *2	DC reactor connection [P1, P(+)] *2						
				[L1/R, L2/S, L3/T] *2	Inverter's grounding [EG]								
Three-phase 400 V	0.75	VXA2A5#-4E	5	2.5	10	2.5	Built-in DC reactor	0.75	2.5	-			
	1.5	VXA4A1#-4E											
	2.2	VXA5A5#-4E											
	4.0	VXA9#-4E	10								4	6	10
	5.5	VXA13A5#-4E											
	7.5	VXA18A5#-4E											
	11	VXA24A5#-4E	30								4	6	10
	15	VXA32#-4E											
	18.5	VXA39#-4E											
	22	VXA45#-4E	50								6	10	10
	30	VXA60#-4E											
	37	VXA75#-4E											
	45	VXA91#-4E	100	25	25	35							
	55	VXA112#-4E											
	75	VXA150#-4E											
	90	VXA176#-4E	125	70	70	95							
	110	VXA210S-4E											
	132	VXA253S-4E											
	160	VXA304S-4E	175	185	240	300							
	200	VXA377S-4E											
	220	VXA415S-4E											
280	VXA520S-4E	200	240x2	240x2	240x2								
315	VXA585S-4E												
355	VXA650S-4E												
400	VXA740S-4E	500	300	300	120x2								
500	VXA960S-4E												
630	VXA1170S-4E												
710	VXA1370S-4E	600	240x2	240x2	240x2								
800	VXA1370S-4E												
1200	VXA1370S-4E												
1400	VXA1370S-4E	800	300x2	300x2	300x2								
1600	VXA1370S-4E												
1600	VXA1370S-4E												

Note: # Enclosure: M (IP21) or L (IP55).

*1 The frame size and model of the MCCB or RCD/ELCB (with overcurrent protection) will vary, depending on the power transformer capacity. Refer to the JAGUAR VXA User's Manual for details.

*2 The recommended wire size for main circuits is for the 70°C 600 V PVC wires used at an ambient temperature of 40°C.

10. The inverter has been tested with IEC/EN 61800-5-1 2007 Short-circuit Test under the following conditions.

Short-circuit current in the supply: 10,000 A
Maximum 480 V

Conformity with UL standards and CSA standards (cUL-listed for Canada) (Under application)

UL/cUL-listed inverters are subject to the regulations set forth by the UL standards and CSA standards (cUL-listed for Canada) by installation within precautions listed below.

⚠ CAUTION

1. Solid state motor overload protection (motor protection by electronic thermal overload relay) is provided in each model. Use function codes F10 to F12 to set the protection level.
2. Use Cu wire only.
3. Use Class 1 wire only for control circuits.
4. Short circuit rating
"Suitable For Use On A Circuit Of Delivering Not More Than 100,000 rms Symmetrical Amperes, 480 Volts Maximum when protected by Class J Fuses or a Circuit Breaker having an interrupting rating not less than 100,000 rms Symmetrical Amperes, 480 Volts Maximum."
"Integral solid state short circuit protection does not provide branch circuit protection. Branch circuit protection must be provided in accordance with the National Electrical Code and any additional local codes."
5. Field wiring connections must be made by a UL Listed and CSA Certified closed-loop terminal connector sized for the wire gauge involved. Connector must be fixed using the crimp tool specified by the connector manufacturer.
6. All circuits with terminals L1/R, L2/S, L3/T, R0, T0, R1, T1 must have a common disconnect and be connected to the same pole of the disconnect if the terminals are connected to the power supply.

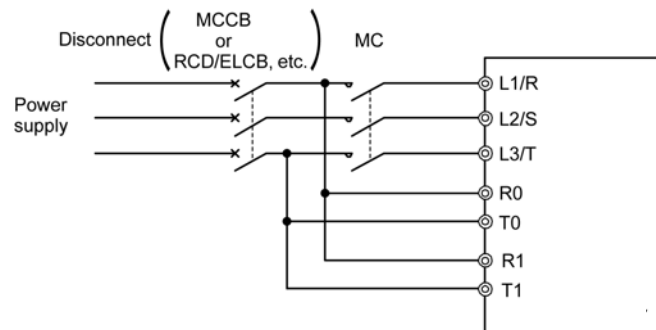

Conformity with UL standards and CSA standards (cUL-listed for Canada) (continued) (Under application)

⚠ CAUTION

7. Install UL certified fuses or circuit breaker between the power supply and the inverter, referring to the table below.

Power supply voltage	Nominal applied motor (kW)	Inverter type	Class J fuse size	Circuit breaker trip size	Required torque lb-in (N•m)			
					Main terminal	Control circuit	Aux. control power supply	Sub main circuit power supply
Three-phase 400V	0.75	VXA2A5#-4E	3	5	15.9 (1.8)	6.1 (0.7)	10.6 (1.2)	-
	1.5	VXA4A1#-4E	6					
	2.2	VXA5A5#-4E	10	10				
	4.0	VXA9#-4E	15	10				
	5.5	VXA13A5#-4E	20	15				
	7.5	VXA18A5#-4E	25	20				
	11	VXA24A5#-4E	35	30	51.3 (5.8)			
	15	VXA32#-4E	50	40				
	18.5	VXA39#-4E	60	50				
	22	VXA45#-4E	70					
	30	VXA60#-4E	100	75	51.3 (5.8)			
	37	VXA75#-4E	125	100				
	45	VXA91#-4E	150	100	119 (13.5)			
	55	VXA112#-4E	200	125				
	75	VXA150#-4E	250	175	239 (27)			
	90	VXA176#-4E	300	200	239 (27)			
	110	VXA210S-4E	350	250	425 (48)			
	132	VXA253S-4E	400	300				
	160	VXA304S-4E	500	350				
	200	VXA377S-4E	600	500				
220	VXA415S-4E	700						
280	VXA520S-4E	1000	600					
315	VXA585S-4E	1000	800					
355	VXA650S-4E	1200						
400	VXA740S-4E	1400	1200					
500	VXA960S-4E	1600						
630	VXA1170S-4E	2000		1400				
710	VXA1370S-4E	2200	1600	10.6 (1.2)				

Note: # Enclosure: M (IP21) or L (IP55).

Conformity with UL standards and CSA standards (cUL-listed for Canada) (continued) (Under application)

⚠ CAUTION

Power supply voltage	Nominal applied motor (kW)	Inverter type	Wire size AWG (mm ²)				
			Main terminal		Control circuit	Aux. control power supply	Sub main circuit power supply
			L1/R, L2/S, L3/T	U, V, W			
			75°C Cu wire	75°C Cu wire			
Three-phase 400V	0.75	VXA2A5#-4E	14 (2.1)	14 (2.1)	18 (0.8)	14 (2.1)	-
	1.5	VXA4A1#-4E					
	2.2	VXA5A5#-4E					
	4.0	VXA9#-4E					
	5.5	VXA13A5#-4E					
	7.5	VXA18A5#-4E					
	11	VXA24A5#-4E	10 (5.3)	10 (5.3)			
	15	VXA32#-4E	10 (5.3)	8 (8.4)			
	18.5	VXA39#-4E	8 (8.4)				
	22	VXA45#-4E					
	30	VXA60#-4E	6 (13.3)	6 (13.3)			
	37	VXA75#-4E	4 (21.2)	2 (33.6)			
	45	VXA91#-4E	4 (21.2)	2 (33.6)			
	55	VXA112#-4E	2 (33.6)	2 (33.6)			
	75	VXA150#-4E	1/0 (53.5)	1/0 (53.5)			
	90	VXA176#-4E	2/0 (67.4)	3/0 (85)			
	110	VXA210S-4E	1/0x2 (53.5x2)	1/0x2 (53.5x2)			
	132	VXA253S-4E		2/0x2 (67.4x2)			
	160	VXA304S-4E	3/0x2 (85x2)	3/0x2 (85x2)			
	200	VXA377S-4E	4/0x2 (107.2x2)	250x2 (127x2)			
	220	VXA415S-4E	250x2 (127x2)	300x2 (152x2)			
	280	VXA520S-4E	400x2 (203x2)	400x2 (203x2)			
	315	VXA585S-4E	300x2 (152x2)	350x2 (177x2)			
	355	VXA650S-4E	400x2 (203x2)	400x2 (203x2)			
400	VXA740S-4E	500x2 (253x2)	500x2 (253x2)				
500	VXA960S-4E	350x3 (177x3)	400x3 (203x3)				
630	VXA1170S-4E	500x3 (253x3)	600x3 (304x2)				
710	VXA1370S-4E	600x3 (304x3)	500x4 (253x4)				

Note: # Enclosure: M (IP21) or L (IP55).

Table of Contents

Preface	i	5.5 P Codes.....	5-11
■ Safety precautions	i	5.6 H Codes.....	5-12
Conformity to the Low Voltage Directive in the EU	vi	5.7 J Codes.....	5-15
Conformity with UL standards and CSA standards (cUL-listed for Canada) (Under application)	ix	5.8 d Codes.....	5-25
Chapter 1 BEFORE USE.....	1-1	5.9 U Codes.....	5-25
1.1 Acceptance Inspection and Appearance of Product.....	1-1	5.11 y Codes.....	5-31
1.2 Precautions for Using Inverters	1-2	5.12 T Codes.....	5-32
Chapter 2 MOUNTING AND WIRING THE INVERTER...2-1	2-1	5.13 K Codes.....	5-33
2.1 Installing the Inverter	2-1	5.14 o Codes.....	5-35
2.2 Wiring	2-1	Chapter 6 TROUBLESHOOTING.....	6-1
2.2.1 Removing and mounting the front cover and the wiring plate.....	2-1	6.1 Alarm Codes.....	6-1
2.2.2 Recommended wire sizes.....	2-3	Chapter 7 MAINTENANCE AND INSPECTION.....	7-1
2.2.3 Terminal arrangement diagrams and screw specifications	2-4	7.1 Daily Inspection	7-1
2.2.4 Terminal functions and wiring order	2-8	7.2 Periodic Inspection	7-1
2.2.5 Connection diagrams.....	2-11	7.3 List of Periodic Replacement Parts	7-2
2.2.6 Setting the switches.....	2-19	7.4 Inquiries about Product and Guarantee.....	7-3
2.2.7 Mounting and connecting the keypad to the panel.....	2-19	Chapter 8 SPECIFICATIONS	8-1
Chapter 3 NAMES AND FUNCTIONS OF KEYPAD COMPONENTS	3-1	8.1 Standard Model	8-1
Chapter 4 RUNNING THE MOTOR FOR A TEST	4-1	8.2 External Dimensions	8-3
4.1 Checking Prior to Powering ON.....	4-1	Chapter 9 CONFORMITY WITH STANDARDS	9-1
4.2 Powering ON and Checking	4-1	9.1 Compliance with European Standards	9-1
4.3 Configuring the Function Code Data Before Test Run	4-2	9.2 Conformity to the Lower Voltage Directive in the EU.....	9-1
4.4 Running the Inverter for Motor Operation Check....	4-2	9.3 Compliance with EMC Standards	9-1
4.5 Preparation for Practical Operation	4-3	9.3.1 General.....	9-1
Chapter 5 FUNCTION CODES.....	5-1	9.3.2 Recommended installation procedure	9-1
5.1 Overview	5-2	9.3.3 Leakage current of the EMC filter	9-3
5.2 F Codes.....	5-3	9.4 Harmonic Component Regulation in the EU.....	9-4
5.3 E Codes.....	5-5	9.4.1 General comments	9-4
5.4 C Codes	5-10	9.4.2 Compliance with IEC/EN 61000-3-2	9-4
		9.4.3 Compliance with IEC/EN 61000-3-12	9-4
		9.5 Compliance with UL Standards and Canadian Standards (cUL certification) (Under application) ...	9-4
		9.5.1 General.....	9-4
		9.5.2 Considerations when using JAGUAR VXA in systems to be certified by UL and cU	9-4

Chapter 1 BEFORE USE

1.1 Acceptance Inspection and Appearance of Product

Unpack the package and check the following:

- (1) An inverter and instruction manual (this book) are contained in the package.
- (2) The inverter has not been damaged during transportation—there should be no dents or parts missing.
- (3) The inverter is the type you ordered. You can check the type and specifications on the main nameplate. (A total of four nameplates and warning plates are attached to the inverter as shown below.)

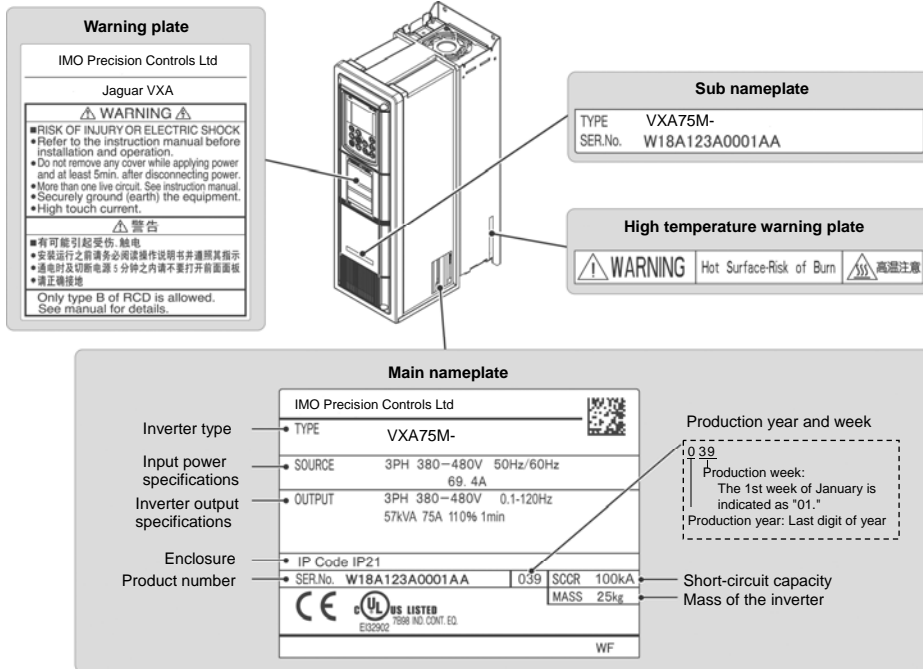

Options & ordering codes

VXA	75	M	-	4E
<i>Motor (kw)</i>				E Integrated EMC filter
0.75	2A5			M Enclosure - IP21
1.5	4A1			L Enclosure - IP55
2.2	5A5			S Enclosure - IP00
4	9			
5.5	13A5			
7.5	18A5			
11	24A5			
15	32			
18.5	39			
22	45			
30	60			
37	75			
45	91			
55	112			
75	150			
90	176			
110	210			
132	253			
160	304			
				<i>Motor (kw)</i>
				200 377
				220 415
				280 520
				315 585
				355 650
				400 740
				500 960
				630 1170
				710 1370

Chapter 2 MOUNTING AND WIRING THE INVERTER

2.1 Installing the Inverter

(1) Mounting base

Install the inverter on a base made of metal or other non-flammable material. Do not mount the inverter upside down or horizontally.

(2) Clearances

Ensure that the minimum clearances indicated in Figure 2.1 and Table 2.1 are maintained at all times. When installing the inverter in the panel of your system, take extra care with ventilation inside the panel as the ambient temperature easily rises. Do not install the inverter in a small panel with poor ventilation.

■ When mounting two or more inverters

When mounting two or more inverters in the same unit or panel, basically lay them out side by side. When mounting them necessarily one above the other, be sure to separate them with a partition plate or the like so that any heat radiating from an inverter will not affect the one(s) above.

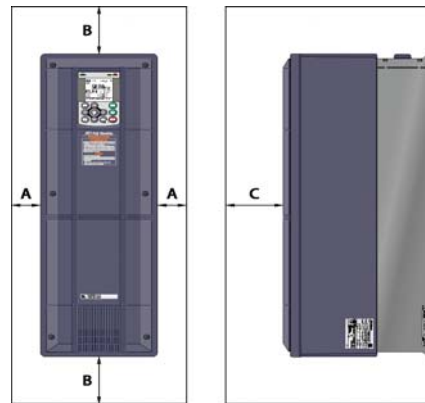

Figure 2.1 Mounting Direction and Required Clearances

Table 2.1 Clearances (mm)

Inverter capacity	A	B	C
0.75 to 90 kW	10	100	100
110 to 280 kW	50		
315 to 710 kW		150	150

C: Space required in front of the inverter unit

2.2 Wiring

Before wiring, remove the front cover and wiring plate and then set cable glands or conduits on the wiring plate. After wiring, mount the wiring plate and front cover back into place. (The cable glands or conduits should be prepared by the customer.)

2.2.1 Removing and mounting the front cover and the wiring plate

(1) 90 kW or less

- ① Loosen the (four or six) screws on the front cover, hold the right and left ends of the front cover, and remove it towards you.
- ② Loosen the four screws on the wiring plate, hold the right and left ends of the wiring plate, and remove it downwards.

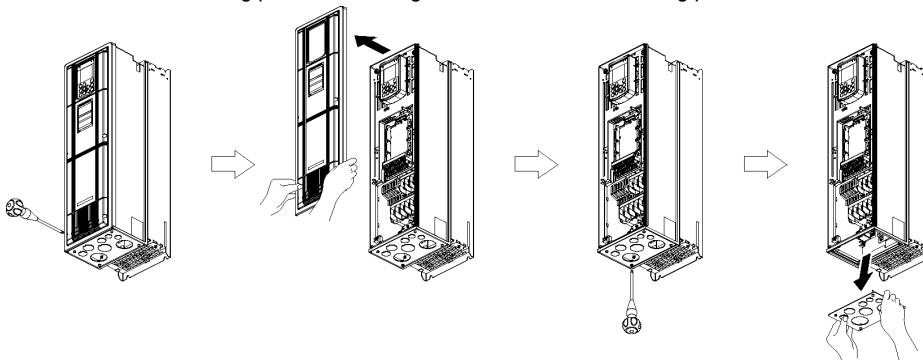

Figure 2.2 Removing the Front Cover and the Wiring Plate (VXA75M-4E)

- Tip**
- The wiring plate can be removed even with the front cover being mounted.
 - To expose the control printed circuit board (control PCB), remove the front cover.

(2) 110 to 710 kW

- ① Loosen the screws on the front cover, hold the right and left ends of the front cover, and slide it up to remove it.
- ② After making the necessary wiring connections, align the top of the front cover with the holes on the unit and reattach the cover by reversing the process illustrated in Figure 2.3.

Tip - To expose the control printed circuit board (control PCB), open the keypad case.

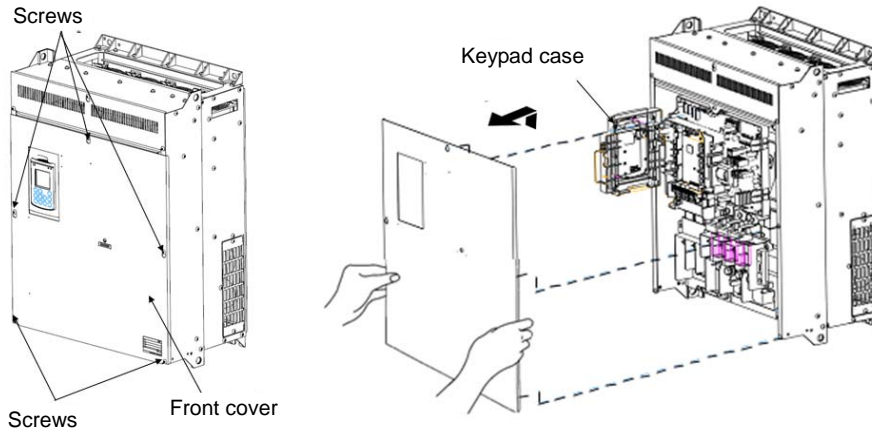

Figure 2.3 Removing the Front Cover and the Wiring Plate (VXA210S-4E)

(3) Punching out semi-perforated sections in the wiring plate and setting cable glands or conduits

- ① Lightly tap the semi-perforated sections from the inside of the wiring plate using the hand grip of a screwdriver or the like to punch them out.
- ② Set the cable glands or conduits on the wiring plate and then carry out wiring.

Note Take care not to get injured by the edge of the parts.

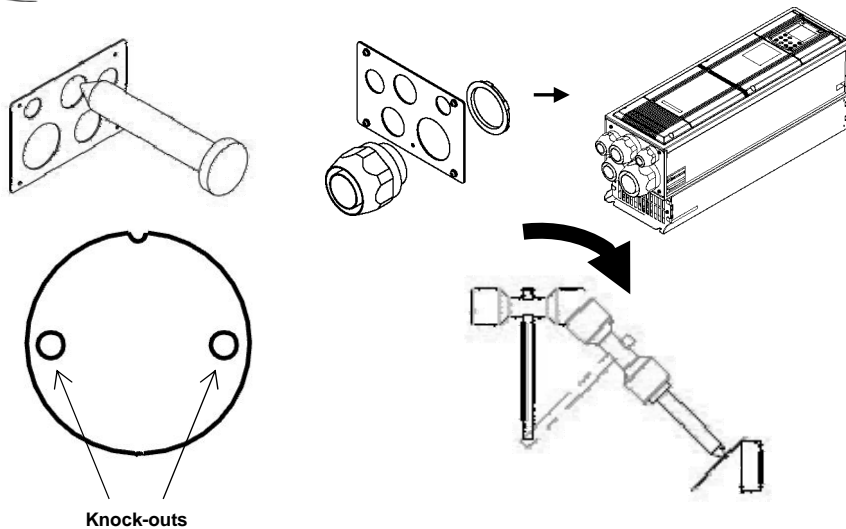
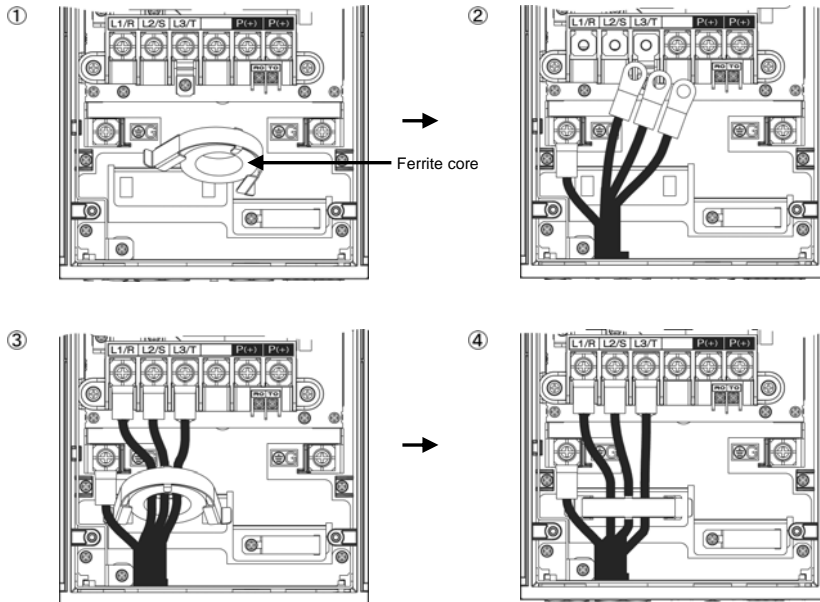

Figure 2.4 Punching Out Semi-perforated Sections in the Wiring Plate and Setting Cable Glands or Conduits

(4) Wiring the main circuit power input wires

For inverters of 11 to 90 kW, follow the wiring procedure given below for smooth wiring.

- ① Remove the screws and press the ends of the ferrite core support inwards to release the ferrite core from the main circuit terminal block.
- ② Connect the inverter grounding wire.
- ③ Pass the main circuit power input wires of the inverter through the ferrite core and then connect those wires to the terminal block.
- ④ Put the ferrite core and its support back into place.



(5) Mounting the wiring plate and the front cover

After wiring, mount the wiring plate and front cover back into place. (Tightening torque: 1.8 N•m (M4), 3.5 N•m (M5))

2.2.2 Recommended wire sizes

For the recommended wire sizes for the main circuits, refer to the "Conformity to the Low Voltage Directive in the EU" and "Conformity with UL standards and CSA standards (cUL-listed for Canada) (Under application)" given in Preface. Crimp-style terminals for the main circuits should have insulation, insulation tubes, or similar treatment.

2.2.3 Terminal arrangement diagrams and screw specifications

The tables and figures given below show the screw specifications and terminal arrangement diagrams. Note that the terminal arrangements differ depending on the inverter capacity.

Note Do not make wiring to unassigned main circuit terminals that are marked with (NC) in the figures given below. Doing so may break the inverter.

(1) Main circuit terminals

Table 2.2 Main Circuit Terminals

Power supply voltage	Nominal applied motor (kW)	Inverter type	Refer to:	Main circuit terminals		Grounding terminals		Aux. control power supply		Sub main circuit power supply [R1, T1]	
				Screw size	Tightening torque lb-in (N·m)	Screw size	Tightening torque lb-in (N·m)	Screw size	Tightening torque lb-in (N·m)	Screw size	Tightening torque lb-in (N·m)
Three-phase 400V	0.75	VXA2A5#-4E	Figure A	M4	15.9 (1.8)	M4	15.9 (1.8)	M3.5	10.6 (1.2)	-	-
	1.5	VXA4A1#-4E									
	2.2	VXA5A5#-4E									
	4.0	VXA9#-4E									
	5.5	VXA13A5#-4E									
	7.5	VXA18A5#-4E	Figure B	M6	51.3 (5.8)	M6	51.3 (5.8)				
	11	VXA24A5#-4E									
	15	VXA32#-4E									
	18.5	VXA39#-4E	Figure C	M6	51.3 (5.8)	M6	51.3 (5.8)				
	22	VXA45#-4E									
	30	VXA60#-4E	Figure D	M8	119 (13.5)	M8	119 (13.5)				
	37	VXA75#-4E									
	45	VXA91#-4E	Figure E	M10	239 (27)	M10	239 (27)				
	55	VXA112#-4E									
	75	VXA150#-4E	Figure F	M10	239 (27)	M8	119 (13.5)				
	90	VXA176#-4E									
	110	VXA210S-4E	Figure G	M12	425 (48)	M10	239 (27)				
	132	VXA253S-4E									
	160	VXA304S-4E	Figure H	M12	425 (48)	M10	239 (27)				
	200	VXA377S-4E									
220	VXA415S-4E	Figure I	M12	425 (48)	M10	239 (27)					
280	VXA520S-4E										
315	VXA585S-4E	Figure J	M12	425 (48)	M10	239 (27)					
355	VXA650S-4E										
400	VXA740S-4E	Figure K	M12	425 (48)	M10	239 (27)					
500	VXA960S-4E										
630	VXA1170S-4E	Figure K	M12	425 (48)	M10	239 (27)					
710	VXA1370S-4E										

Note: # Enclosure: M (IP21) or L (IP55).

Figure A

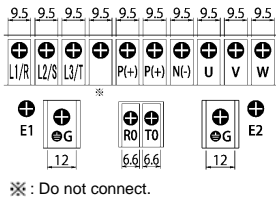

Figure B

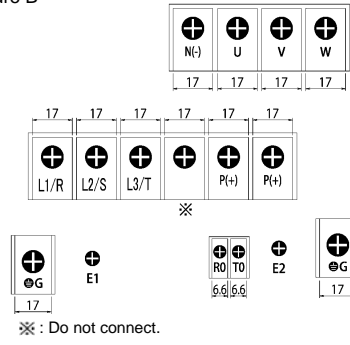

Figure C

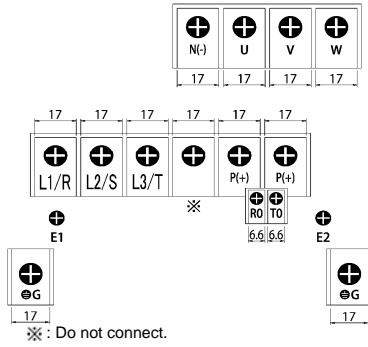

Figure D

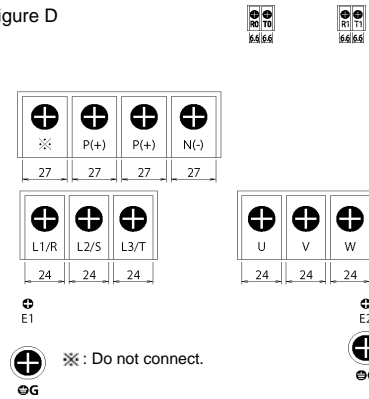

Figure E

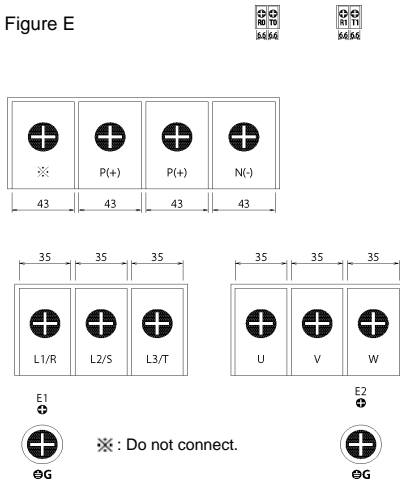

Figure F

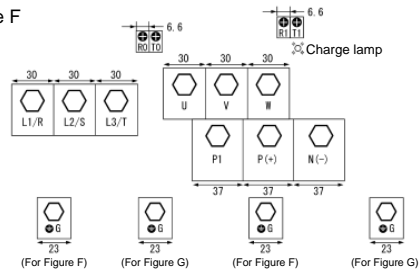

Figure G / Figure H

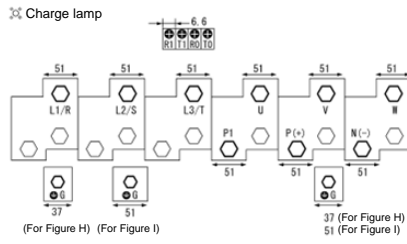

Figure I Charge lamp

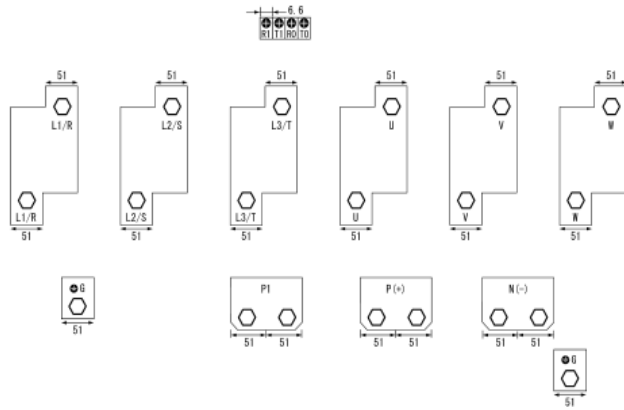

Figure J Charge lamp

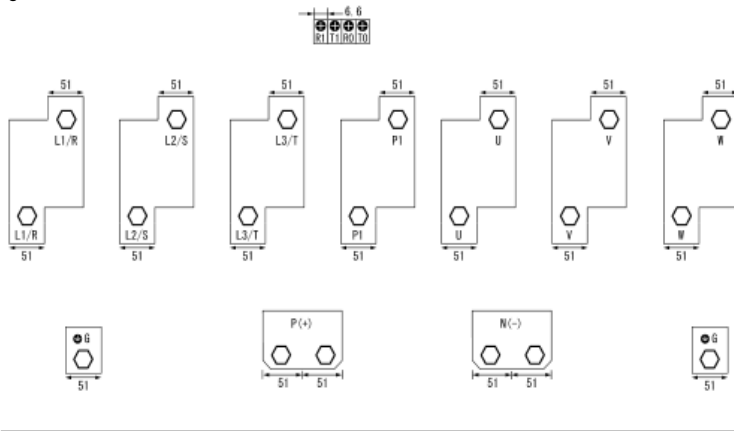
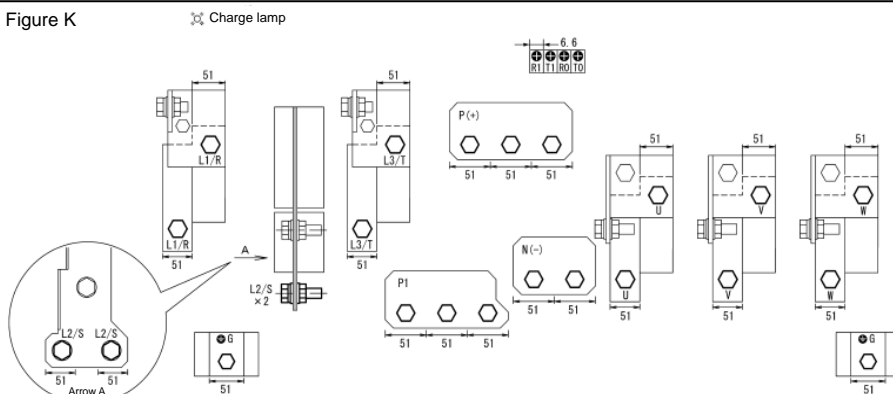
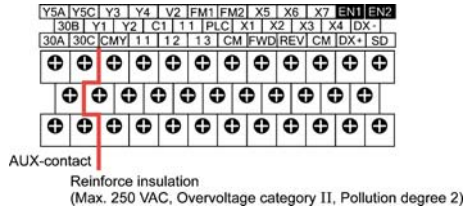

Figure K



(2) Arrangement of control circuit terminals

■ Screw type of terminal block
(common to all inverter types)



■ Europe type of terminal block
(common to all inverter types)

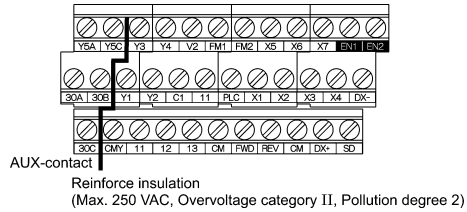
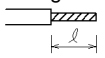

Table 2.3 Control Circuit Terminals

Terminal block type	Screw specifications		Recommended wire size (mm ²)	Type of screwdriver (tip shape)	Wire strip length 	Gauge No. of wire insertion slot
	Screw size	Tightening torque				
Screw type	M3	0.7 N·m	0.75 mm ² (AWG18)	-	-	-
Europe type		0.5 to 0.6 N·m		Flat screwdriver (0.6 mm x 3.5 mm)	6 mm	A1*





*In conformity with the IEC/EN 60947-1

2.2.4 Terminal functions and wiring order

Main circuit terminals and grounding terminals

The table below shows the order of wiring and terminal functions. Carry out wiring in the order shown below.

Table 2.4 Order of Wiring and Functions of Main Circuit Terminals

Classification	Order of wiring	Name	Symbol	Functions
Main circuit (Note)	①	Primary grounding terminals for inverter enclosure	 G	Two grounding terminals ( G) are not exclusive to the power supply wiring (primary circuit) or motor wiring (secondary circuit). Be sure to ground either of the two grounding terminals for safety and noise reduction.
	②	Secondary grounding terminals for motor Inverter output terminals	 G U, V, W	Connect the secondary grounding wire for the motor to the grounding terminal ( G). Connect the three wires of the 3-phase motor to terminals U, V, and W, aligning the phases each other. (*1)
	③	Auxiliary control power input terminals	R0, T0	Connect the same AC power as for the main circuit to these terminals as a control circuit power backup.
	④	Auxiliary main circuit power input terminals	R1, T1	It is not normally necessary to connect anything to these terminals. They are used when connecting to a DC bus. For more information, see section 4-11 of the User's Manual. (45kW or greater)
	⑤	DC reactor connection terminals	P1, P(+)	Connect a DC reactor (DCR) to improve the power factor. (110 kW or greater)
	⑥	DC link bus terminals	P(+), N(-)	A DC link bus is connectable to these terminals. When you need to use the DC link bus terminals P(+) and N(-), consult your IMO.
	⑦	Main circuit power input terminals	L1/R, L2/S, L3/T	The three-phase input power lines are connected to these terminals. (*2) If the power wires are connected to other terminals, the inverter will be damaged when the power is turned ON.
	⑧	Switching connectors	CN UX, CN R, CN W	These are the main circuit switching connectors. For more information, see "2.2.5 Switching connectors" in this instruction manual.
Control circuit	⑨	Control circuit terminals	See Table 2.5.	Route the wiring of the control circuit as far from that of the main circuit as possible. Otherwise, electric noise may cause malfunctions. When the Enable function is not to be used, short-circuit terminals [EN1] and [PLC] and terminals [EN2] and [PLC] using jumper wires.

(Note) Do not make wiring to unassigned main circuit terminals (marked with NC). For details about the terminal block, refer to Section 2.2.3 "Terminal arrangement diagrams and screw specifications."

■ Wiring notes

To make the machinery or equipment compliant with the EMC standards, wire the motor and inverter in accordance with the following.

(*1) Use shielded wires for the motor cable and route the cable as short as possible. Firmly clamp the shield to the specified point inside the inverter.

(*2) When wiring the main circuit power input lines of the inverters of 11 to 90 kW, be sure to pass them through a ferrite core.



When shielded wires are not used for the motor cable, remove the motor cable clamps to prevent the cable covering from getting damaged, which makes the machinery or equipment non-compliant with the EMC standards. Wiring the inverter main power input lines without passing them through a ferrite core also makes the machinery or equipment non-compliant with the EMC standards due to increase of noise generated by the inverter, but it does not affect inverter basic operation.

 For details about wiring, refer to Chapter 9, Section 9.3 "Compliance with EMC Standards."

Control circuit terminals

Table 2.5 Names, Symbols and Functions of the Control Circuit Terminals

Classification	Name	Symbol	Functions
Analog input	Power supply for the potentiometer	[13]	Power supply for an external frequency command potentiometer (Variable resistor: 1 to 5kΩ)
	Analog setting voltage input	[12]	External voltage input that commands the frequency externally.
	Analog setting current input PTC thermistor input	[C1]	External current input that commands the frequency externally. Connection of a PTC (Positive Temperature Coefficient) thermistor for motor protection.
	Analog setting voltage input	[V2]	External voltage input that commands the frequency externally.
	Analog common	[11]	Common terminal for analog input signals.
Digital input	Digital input 1 to Digital input 7	[X1] to [X7]	(1) Various signals such as "Coast to a stop," "Enable external alarm trip," and "Select multi-frequency" can be assigned to terminals [X1] to [X7], [FWD] and [REV] by setting function codes E01 to E07, E98, and E99. (2) Input mode, i.e. SINK/SOURCE, is changeable by using the slide switch SW1. (3) The logic value (1/0) for ON/OFF of the terminals [X1] to [X7], [FWD], or [REV] can be switched. If the logic value for ON of the terminal [X1] is "1" in the normal logic system, for example, OFF is "1" in the negative logic system and vice versa.
	Run forward command	[FWD]	Short-circuiting terminals [FWD] and [CM] runs the motor in the forward direction and opening them decelerates the motor to a stop.
	Run reverse command	[REV]	Short-circuiting terminals [REV] and [CM] runs the motor in the reverse direction and opening them decelerates the motor to a stop.
	Enable input 1 Enable input 2	[EN1] [EN2]	(1) Opening the circuit between terminals [EN1] and [PLC] or terminals [EN2] and [PLC] stops the operation of the inverter output transistor. (2) The input mode of terminals [EN1] and [EN2] is fixed at the SOURCE mode. No switching to the SINK mode is possible. (3) If either one of [EN1] and [EN2] is OFF, an alarm occurs.
	PLC signal power	[PLC]	Connects to the output signal power supply of Programmable Logic Controller (PLC).
	Digital input common	[CM]	Common terminals for digital input signals
Analog output	Analog monitor	[FM1] [FM2]	These terminals output monitor signals for analog DC voltage (0 to +10 V) or analog DC current (4 to 20 mA/0 to 20 mA).
	Analog common	[11]	Common terminal for analog output signals.
Transistor output	Transistor output 1 to Transistor output 4	[Y1] to [Y4]	Both the SINK and SOURCE modes are supported. (1) Various signals such as "Inverter running," "Frequency arrival signal," and "Motor overload early warning" can be assigned to terminals [Y1] to [Y4] by setting function code E20 to E23. (2) The logic value (1/0) for ON/OFF of the terminals between one of [Y1] to [Y4] and [CMY] can be switched. If the logic value for ON between one of [Y1] to [Y4] and [CMY] is "1" in the normal logic system, for example, OFF is "1" in the negative logic system and vice versa.
	Transistor output common	[CMY]	Common terminal for transistor output signals

Table 2.5 Names, Symbols and Functions of the Control Circuit Terminals (Continued)

Classification	Name	Symbol	Functions
Relay output	General-purpose relay output	[Y5A/C]	(1) Any one of output signals that can be assigned to terminals [Y1] to [Y4] can also be assigned to this relay contact, as a general-purpose relay output. (2) Whether excitation or non-excitation causes this terminal to output an alarm can be switched.
	Alarm relay output (for any error)	[30A/B/C]	(1) When the protective function is activated, this terminal outputs a contact signal (1C) to stop the motor. (2) Any one of output signals that can be assigned to terminals [Y1] to [Y4] can also be assigned to this relay contact as a multipurpose relay output, to use it for signal output. (3) Whether excitation or non-excitation causes this terminal to output an alarm can be switched.
Communication	RS-485 communications port 2 (On the terminal block)	[DX+]/ [DX-]/ [SD]	These I/O terminals are used as a communications port that transmits data through the RS-485 multipoint protocol between the inverter and a computer or other equipment such as a PLC.
	RS-485 communications port 1 (For connection of the keypad)	RJ-45 connector	Used to connect the keypad to the inverter. The inverter supplies the power to the keypad via the extension cable for remote operation.
	USB port (On the control printed circuit board)	CN10	Used as a USB port connector (mini B) that connects the inverter to a computer. This connector enables connection with the inverter support loader.
Battery	Battery connection	CN11	Connector for an optional battery.

2.2.5 Connection diagrams

This section shows connection diagrams with the Enable input function used.

SINK mode.

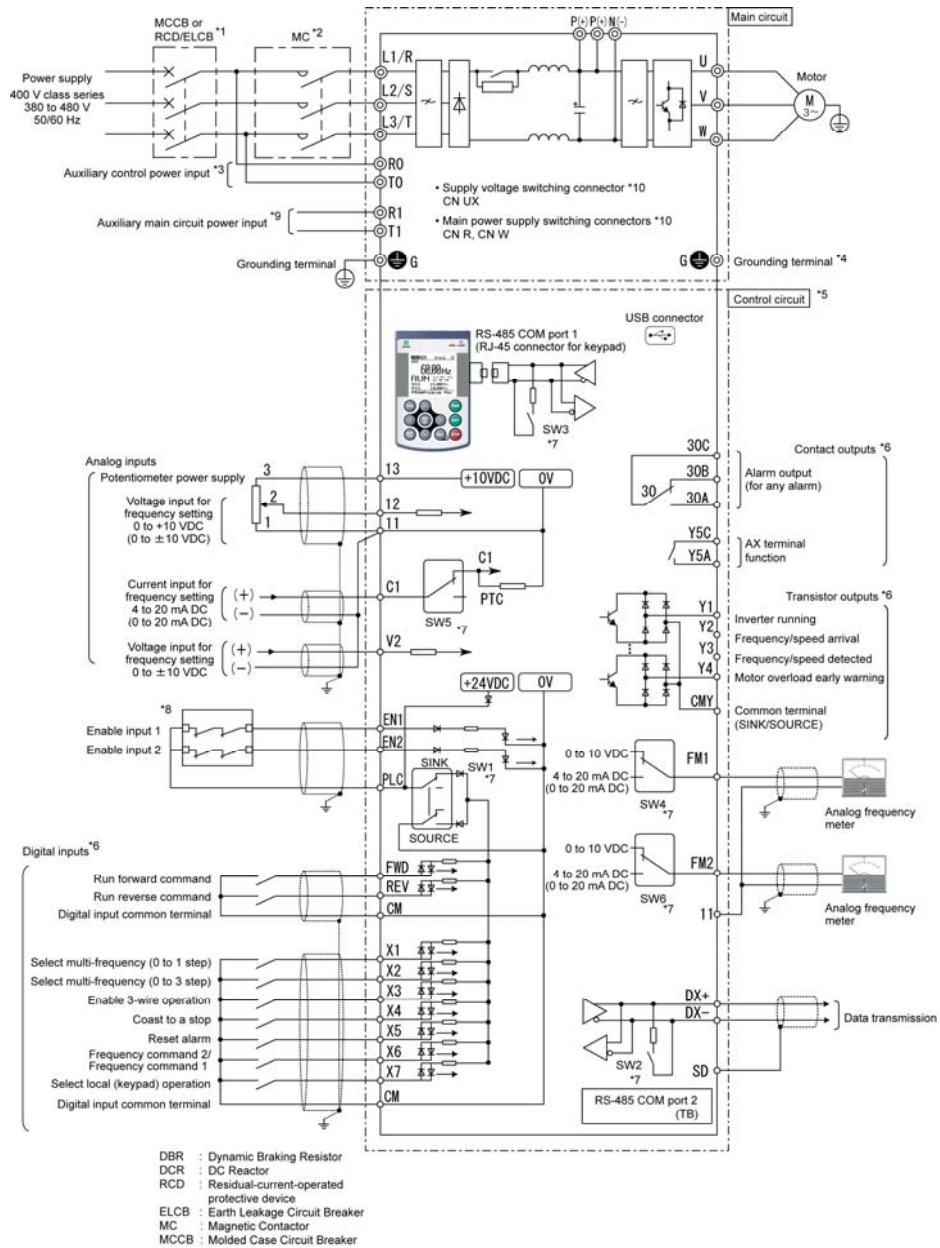

SOURCE mode input by factory default.

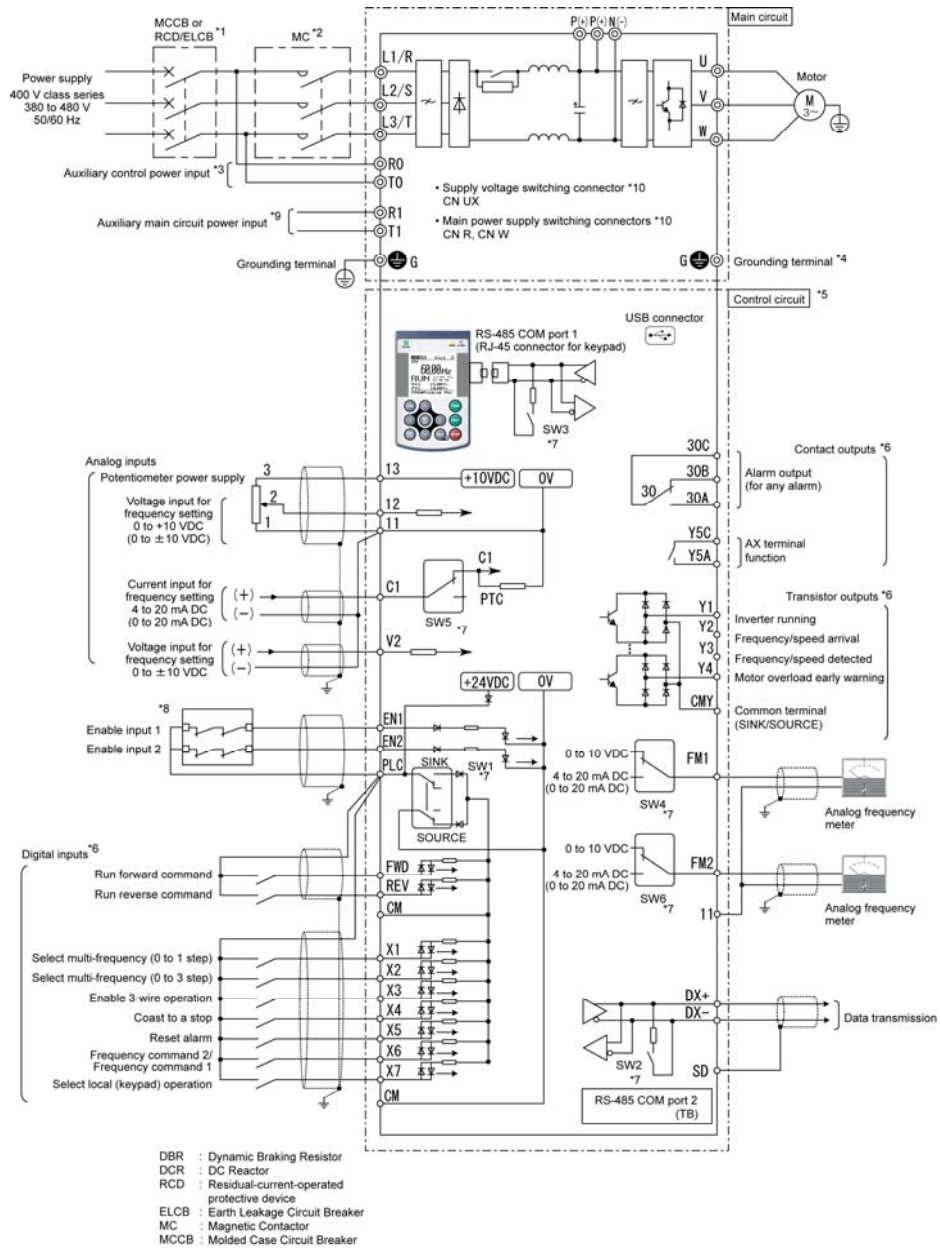

SINK mode input by factory default (110 kW or greater)

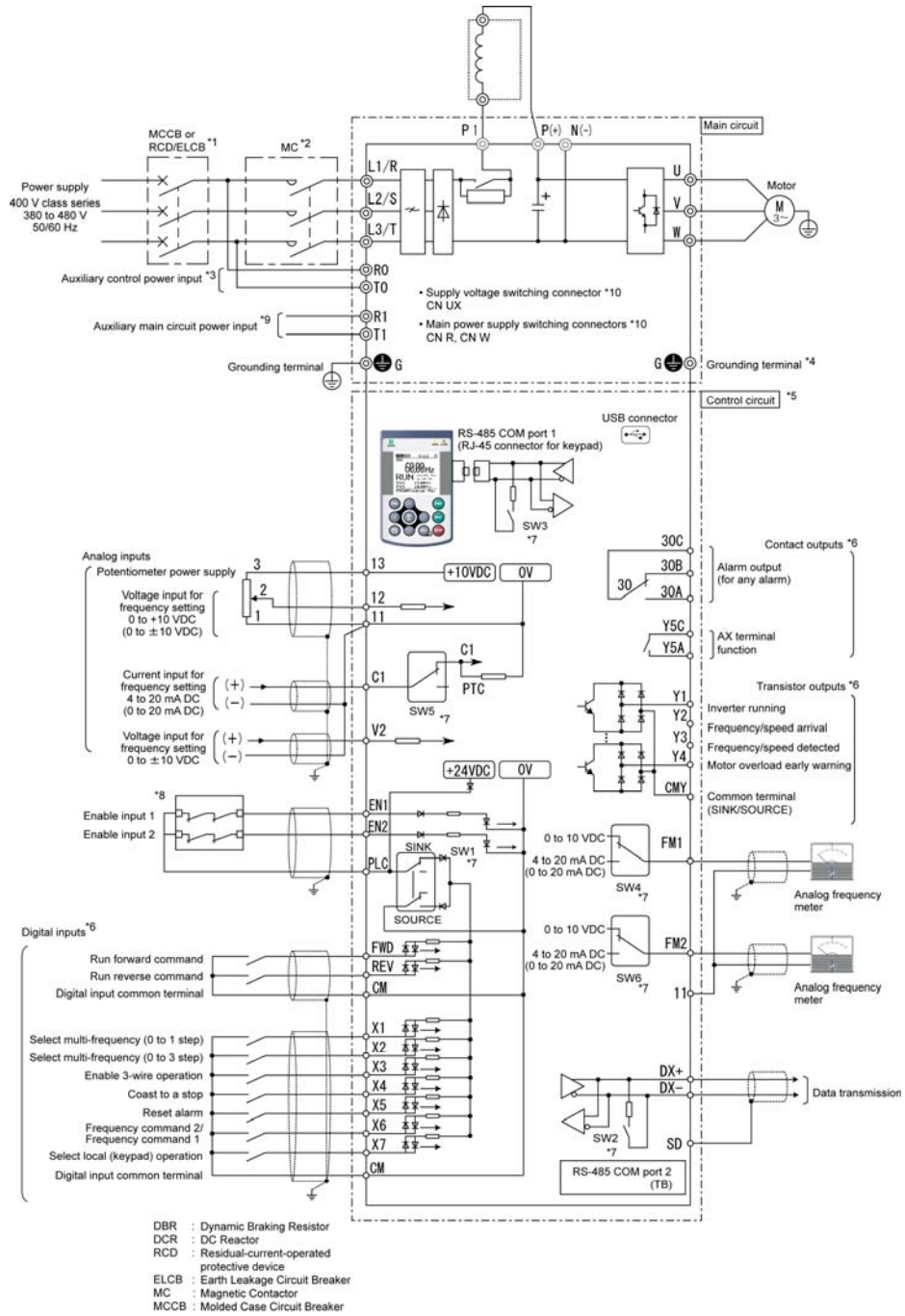

SOURCE mode input by factory default (110 kW or greater)

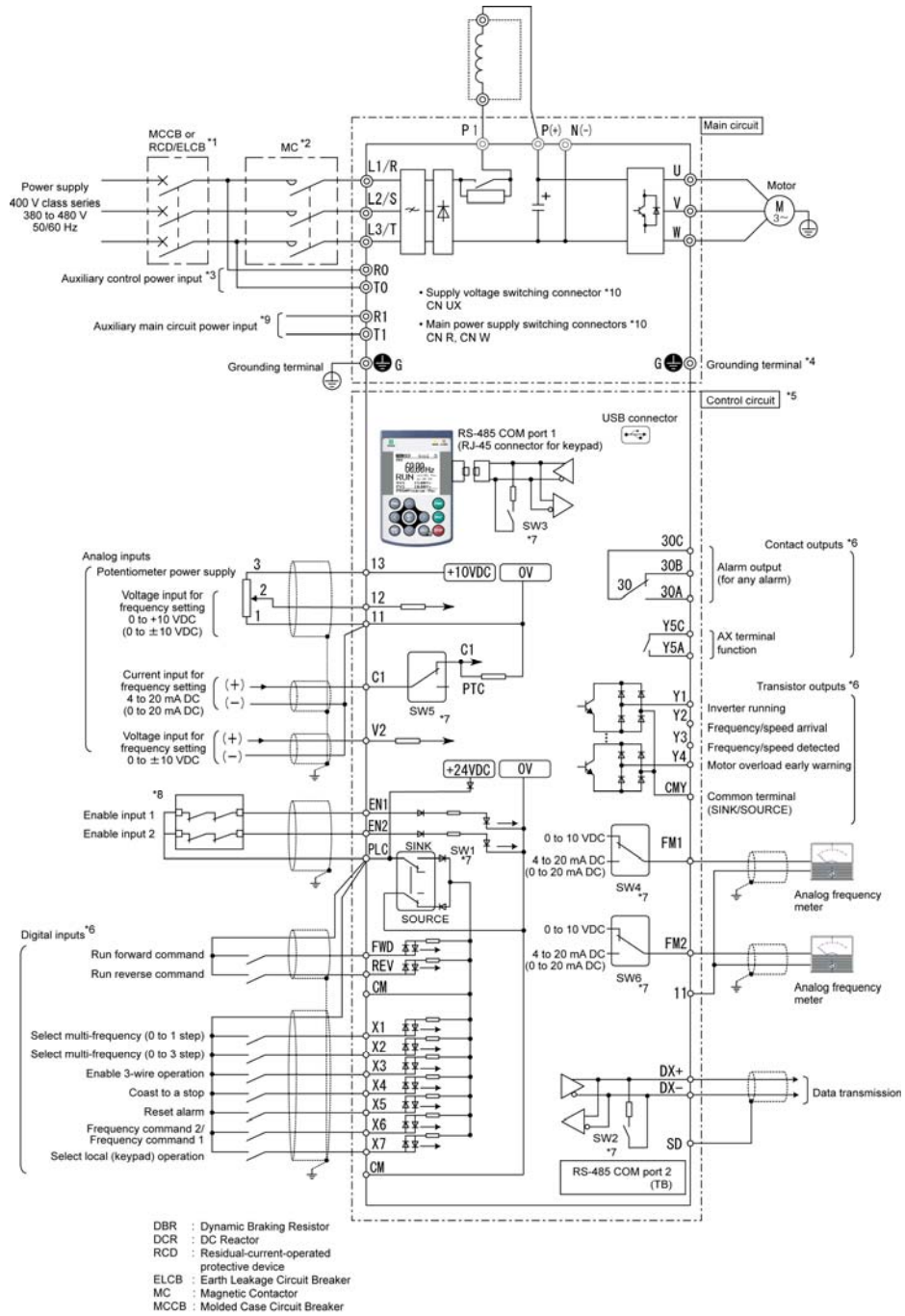

- *1 Install a recommended molded case circuit breaker (MCCB) or residual-current-operated protective device (RCD)/earth leakage circuit breaker (ELCB) (with overcurrent protection function) in the primary circuit of the inverter to protect wiring. Ensure that the circuit breaker capacity is equivalent to or lower than the recommended capacity.
- *2 Install a magnetic contactor (MC) for each inverter to separate the inverter from the power supply, apart from the MCCB or RCD/ELCB, when necessary.
Connect a surge absorber in parallel when installing a coil such as the MC or solenoid near the inverter.
- *3 To retain an alarm output signal **ALM** issued on inverter's programmable output terminals by the protective function or to keep the keypad alive even if the main power has shut down, connect these terminals to the power supply lines. Even without power supply to these terminals, the inverter can run.
When these terminals are connected to the power supply lines, shutting down the MC being used for main power ON/OFF cannot power off all live parts. Be sure to shut down all circuits with a disconnecting switch (DS).
- *4 A grounding terminal for a motor. Use this terminal if needed.
- *5 For control signal wires, use twisted or shielded-twisted wires. When using shielded-twisted wires, connect the shield of them to the common terminals of the control circuit. To prevent malfunction due to noise, keep the control circuit wiring away from the main circuit wiring as far as possible (recommended: 10 cm or more). Never install them in the same wire duct. When crossing the control circuit wiring with the main circuit wiring, set them at right angles.
- *6 The connection diagram shows factory default functions assigned to digital input terminals [X1] to [X7], [FWD] and [REV], transistor output terminals [Y1] to [Y4], and relay contact output terminals [Y5A/C] and [30A/B/C].
- *7 Slide switches on the control printed circuit board (control PCB). Use these switches to customize the inverter operations. For details, refer to Section 2.2.6 "Setting up the slide switches."
- *8 When the Enable function is not to be used, short-circuit terminals [EN1] and [PLC] and terminals [EN2] and [PLC] using jumper wires. For opening and closing the hardware circuit between terminals [EN1] and [PLC] and between [EN2] and [PLC], use safety components such as safety relays and safety switches. Be sure to use shielded wires exclusive to terminals [EN1] and [PLC] and terminals [EN2] and [PLC]. (Do not put them together with any other control signal wire in the same shielded core.)
- *9 It is not normally necessary to connect anything to these terminals. They are used when connecting to a DC bus. (45kW or greater)
- *10 These are the main circuit switching connectors. For more information, see "2.2.5 Switching connectors" in this instruction manual.

• **Switching connectors**

■ Supply voltage switching connector (CN UX)

Inverters with a capacity of 45 kW or greater have a supply voltage switching connector (CN UX). If the power supply being connected to the main circuit power input terminals (L1/R, L2/S, L3/T) or auxiliary main circuit power input terminals (R1, T1) satisfies the conditions listed below, change the CN UX connector to the U2 position. Otherwise, use the connector in the factory-default U1 position.

For more detailed switching guidelines, see Figures 2.5 and 2.6 on the following page.

(a) 45 to 132 kW

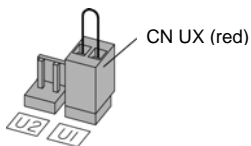
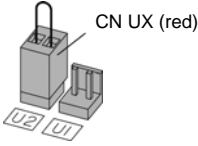
Setting		
Applied voltage	398 to 440 V/50 Hz, 430 to 480 V/60 Hz (Factory default)	380 to 398 V/50 Hz, 380 to 430 V/60 Hz

Note The allowable voltage fluctuation range is +10% to -15%.

(b) 160 to 710 kW

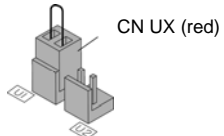
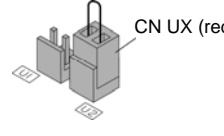
Setting		
Applied voltage	398 to 440V/50Hz, 430 to 480V/60Hz (Factory default)	380 to 398V/50Hz, 380 to 430V/60Hz

Note The allowable voltage fluctuation range is +10% to -15%.

■ Main power supply switching connectors (CN R, CN W) (45 kW or greater)

In its standard specifications, the JAGUAR VXA supports DC power supply input. However, inverters with a capacity of 45 kW or greater have components that are driven internally by an AC power supply and therefore require a supply of AC power. Consequently, when using the inverter with a DC power supply, it is necessary to switch the CN R connector to the **NC** position and the CN W connector to the **73X** position (45 kW to 90 kW) or the **FAN** position (110 kW or greater), and to connect the designated AC power supply to the auxiliary main circuit power input terminals (R1, T1).

For more detailed switching guidelines, see Figures 2.5 and 2.6 on the following page.

(a) 45 to 132 kW

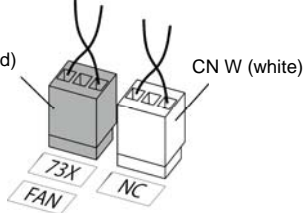
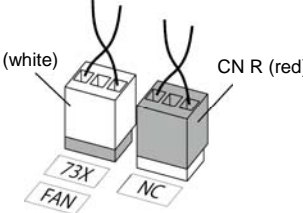
Setting		
Application	When not using the R1 and T1 terminals (Factory default)	When using the R1 and T1 terminals <ul style="list-style-type: none"> DC bus input type Used in combination with a PWM converter.

(b) 160kW to 710kW

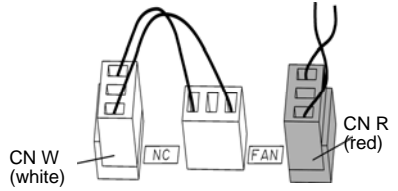
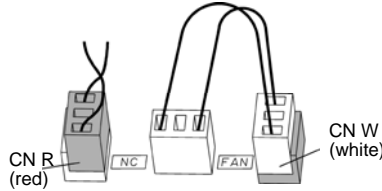
Setting		
Application	When not using the R1 and T1 terminals (Factory default)	When using the R1 and T1 terminals <ul style="list-style-type: none"> DC bus input type Used in combination with a PWM converter.

Note

- In the factory-default state, the main power supply switching connector CN R is set to **73X** (45 to 90 kW) or **FAN** (110 kW or greater), and CN W is set to **NC**. When not using the inverter with DC power supply input, do not switch the connectors. Use of improper main power supply switching connector settings may result in a malfunction such as a cooling fin overheat (OH1) or charging circuit error (PbF).
- When using this product in combination with a PWM converter, refer to the instructions given in the JAGUAR VXA User's Manual.

■ Connector locations

The switching connectors can be found in the following locations on the power supply printed circuit board:

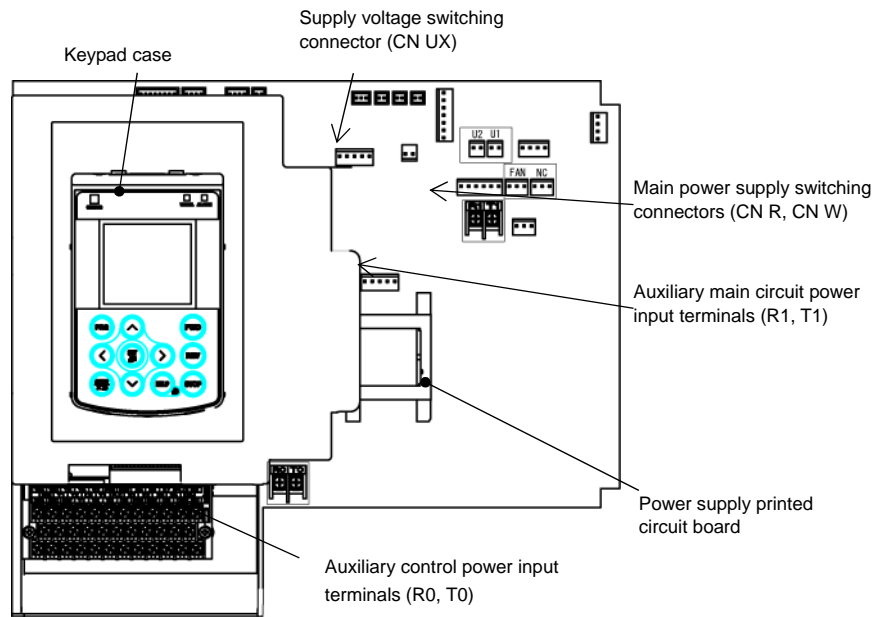
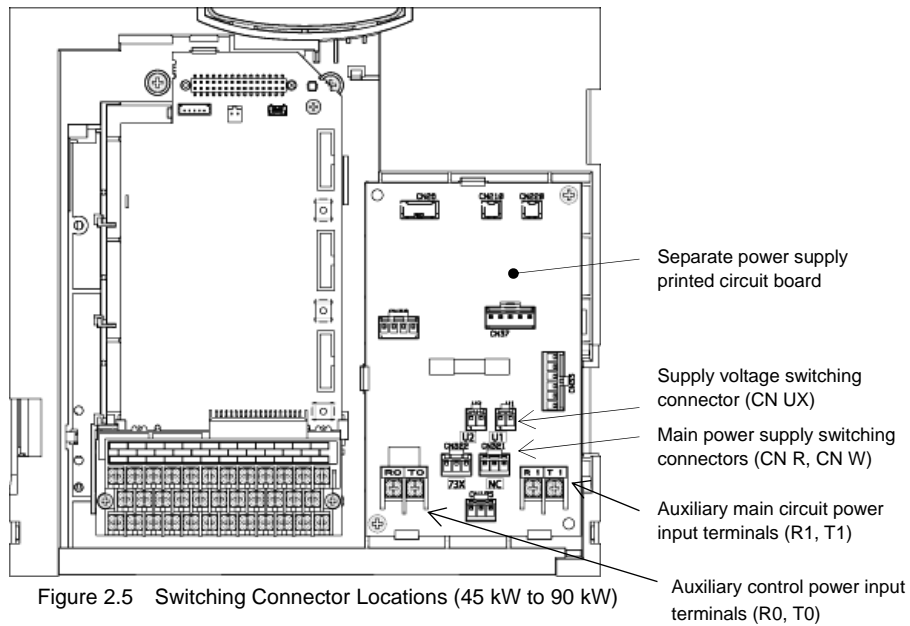

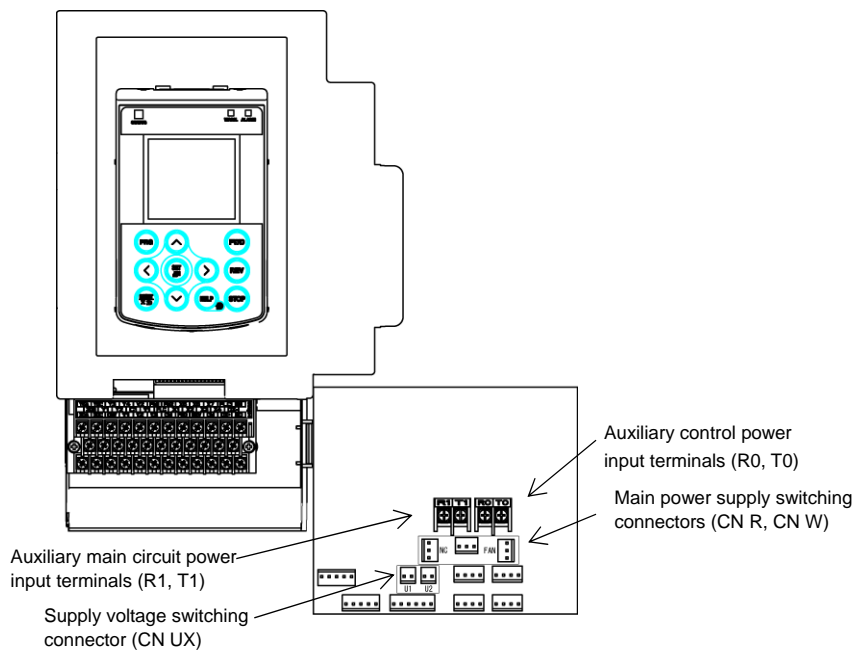
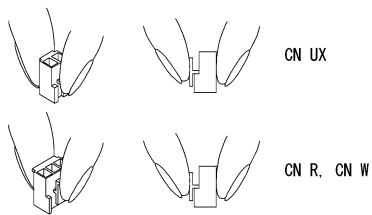

Figure 2.7 Switching Connector Locations (160 kW or greater)



Note

To remove a connector, squeeze the top of the latch between your fingers to release the fastener and pull off the connector. To attach a connector, push it until it makes a clicking sound to ensure that the fastener is securely seated.

Figure 2.8 Attaching and Removing a Switching Connector (45 kW or greater)

2.2.6 Setting the switches

Switching the slide switches located on the control PCB (see Figure 2.9) allows you to customize the operation mode of the analog output terminals, digital I/O terminals, and communications ports.

To access the slide switches, remove the front cover so that you can see the control PCB.

 For details on how to remove the front cover, refer to Section 2.2.1.

Table 2.6 lists function of each slide switch.

Table 2.6 Function of Slide Switches

Switch	Function
SW1	Switches the service mode of the digital input terminals between SINK and SOURCE.
SW2	Switches the terminating resistor of RS-485 communications port on the inverter ON and OFF. (RS-485 communications port 2 on the terminal block)
SW3	Switches the terminating resistor of RS-485 communications port on the inverter ON and OFF. (RS-485 communications port 1 for connecting the keypad)
SW4	Switches the function of terminal [FM1] between VO1 and IO1.
SW5	Switches the function of terminal [C1] between C1 and PTC.
SW6	Switches the function of terminal [FM2] between VO2 and IO2.

Figure 2.9 shows the location of slide switches on the control PCB.

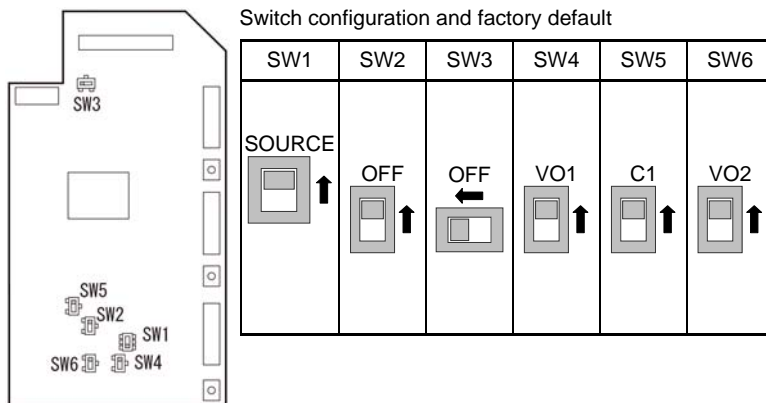

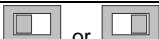





Figure 2.9 Location of the Slide Switches on the Control PCB

 **Note** To move a switch slider, use a tool with a narrow tip (e.g., a tip of tweezers). Be careful not to touch other electronic parts, etc. If the slider is in an ambiguous position, the circuit is unclear whether it is turned ON or OFF and the digital input remains in an undefined state. Be sure to place the slider so that it contacts either side of the switch.

Slider in the correct position	 or 
Slider in an ambiguous position	

2.2.7 Mounting and connecting the keypad to the panel

You can remove the keypad from the inverter unit to mount it on the panel or install it at a remote site (e.g., for operation on hand). Note that the inverter with the keypad removed is rated IP00.

 For detailed instructions on how to mount the keypad on the panel, refer to the JAGUAR VXA User's Manual, Chapter 5, Section 5.2 "Mounting and Connecting a Keypad to the Panel."

Chapter 3 NAMES AND FUNCTIONS OF KEYPAD COMPONENTS

1 LED Indicators

These indicators show the current running status of the inverter.

STATUS (green): Running state
WARN. (yellow): Light alarm state
ALARM (red): Alarm (heavy alarm) state

2 LCD Monitor

This monitor shows the following various information about the inverter according to the operation modes.

- Running status and run command source (e.g., Run/stop and rotation direction)
- Status icons (e.g., timer operation, PID operation, battery state, and password protection state)
- Operation guides for the current screen

3 Programming Keys

These keys are used to:

- Switch the operation modes between Running mode/Alarm mode and Programming mode.
- Reset the alarm states, discard the setting being configured, and cancel the screen transition according to the operation modes.
- Move the cursor to the digit of data to be modified, shift the setting item, and switch the screen.
- Call up the HELP screen for the current display state.

4 Operation Keys

These keys are used to:

- Start running the motor (in the forward/reverse direction).
- Stop the motor.



Chapter 4 RUNNING THE MOTOR FOR A TEST

4.1 Checking Prior to Powering ON

Check the following before powering on the inverter.

- (1) Check that the wiring is correct.
Especially check the wiring to the inverter input terminals L1/R, L2/S and L3/T and output terminals U, V, and W. Also check that the grounding wires are connected to the grounding terminals (G) correctly. See Figure 4.1.
- (2) Check the control circuit terminals and main circuit terminals for short circuits or ground faults.
- (3) Check for loose terminals, connectors and screws.
- (4) Check that the motor is separated from mechanical equipment.
- (5) Make sure that all switches of devices connected to the inverter are turned OFF. Powering on the inverter with any of those switches being ON may cause an unexpected motor operation.
- (6) Check that safety measures are taken against runaway of the equipment, e.g., a defense to prevent people from access to the equipment.

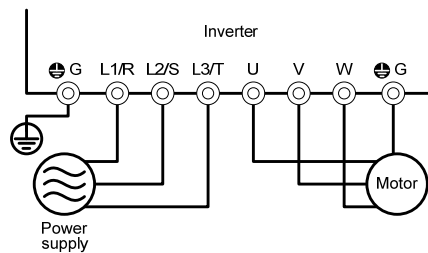

Figure 4.1 Connection of Main Circuit Terminals

4.2 Powering ON and Checking

Turn the power ON and check the following points. The following is a case when no function code data is changed from the factory defaults.

Check that the LCD monitor displays 0.00 Hz (indicating that the reference frequency is 0 Hz) that is blinking. (See Figure 4.2.)

If the LCD monitor displays any number except 0.00 Hz, press the \triangle / ∇ key to set 0.00 Hz.



Figure 4.2 Display of the LCD Monitor after Power-ON



The reactor in the inverter may generate noise due to source voltage distortion, which is not abnormal.

4.3 Configuring the Function Code Data Before Test Run

Configure the function codes listed below according to the motor ratings and your machinery design values. For the motor ratings, check the ratings printed on the motor's nameplate. For your machinery design values, ask system designers about them.

Table 4.1 Configuring Function Code Data

Function code	Name	Function code data	Factory defaults
F04	Base frequency 1	Motor ratings (printed on the nameplate of the motor)	50.0 (Hz)
F05	Rated voltage at base frequency 1		VXA_#-4E 400 (V)
P02	Motor 1 (Rated capacity)		Nominal applied motor capacity
P03	Motor 1 (Rated current)		Rated current of nominal applied motor
P99	Motor 1 selection		0: Motor characteristics 0 (standard motor)
F03	Maximum frequency 1	Machinery design values	50.0 (Hz)
F07	Acceleration time 1 (Note)	(Note) For a test run of the motor, increase values so that they are longer than your machinery design values. If the specified time is short, the inverter may not run the motor properly.	20.00 (s)
F08	Deceleration time 1 (Note)		20.00 (s)

Enclosure: M (IP21) or L (IP55)

For details about the configuration procedure of function codes, refer to the JAGUAR VXA User's Manual, Chapter 5, Section 5.6.3.1 "Configuring function codes."

4.4 Running the Inverter for Motor Operation Check

After completion of preparations for a test run as described above, start running the inverter for motor operation check using the following procedure.

----- **Test Run Procedure** -----

- (1) Turn the power ON and check that the reference frequency 0.00 Hz is blinking on the LCD monitor.
- (2) Set a low reference frequency such as 5 Hz, using \curvearrowright / \curvearrowleft keys. (Check that the frequency is blinking on the LCD monitor.)
- (3) Press the FWD key to start running the motor in the forward direction. (Check that the reference frequency is blinking on the LCD monitor.)
- (4) To stop the motor, press the STOP key.

< Check points during a test run >

- Check that the motor is running in the forward direction.
- Check for smooth rotation without motor humming or excessive vibration.
- Check for smooth acceleration and deceleration.

When no abnormality is found, press the FWD key again to start driving the motor, then increase the reference frequency using \curvearrowright / \curvearrowleft keys. Check the above points again.

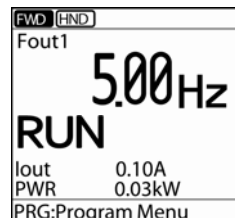

< Modification of motor control function code data >

Modifying the current function code data sometimes can solve an insufficient torque or overcurrent incident. The table below lists the major function codes to be accessed. For details, refer to the JAGUAR VXA User's Manual, Chapter 5 "FUNCTION CODES" or Chapter 6 "TROUBLESHOOTING"

Function code	Name	Modification key points
F07	Acceleration Time 1	If the current limiter is activated due to a short acceleration time and large drive current, prolong the acceleration time.
F08	Deceleration Time 1	If an overvoltage trip occurs due to a short deceleration time, extend the deceleration time.
F09	Torque Boost 1	If the starting motor torque is deficient, increase the torque boost. If the motor with no load is overexcited, decrease the torque boost.

< Remedy to be taken if an alarm ECF (Enable circuit failure) occurs >

Possible Causes	What to Check and Suggested Measures
(1) Poor connection of interface PCB	Check that the interface printed circuit board (PCB) is firmly connected to the inverter unit. Restarting the inverter releases the alarm.
(2) Enable circuit logic error	Check that the logic values of the output of safety switches match with each other (EN1/EN2 = High/High or Low/Low). Restarting the inverter releases the alarm.
(3) Enable circuit (safety circuit) failure detected	If this error persists after the above procedures have been taken, the inverter is defective. Consult IMO. (The alarm cannot be released.)

4.5 Preparation for Practical Operation

After verifying normal motor running with the inverter in a test run, proceed to the practical operation. For details, refer to the JAGUAR VXA User's Manual.

Chapter 5 FUNCTION CODES

This chapter contains overview tables of function codes available for the IMO VXA series of inverters and details of function codes.

Contents

5.1	Overview of Function Codes
5.2	Function Code Tables
5.3	Details of Function Codes
5.3	F codes (Fundamental functions).....
5.5	E codes (Extension terminal functions).....
5.11	C codes (Control functions).....
5.12	P codes (Motor 1 parameters).....
5.13	H codes (High performance functions).....
5.15	H1 codes (High performance functions).....
5.16	J codes (Application functions 1).....
5.16	J1 codes (PID control 1).....
5.20	J2 codes (PID control 2).....
5.22	J4 codes (Pump App Functions)
5.23	J5 codes (External PID control 1).....
5.25	J6 codes (External PID control 2, 3).....
5.28	d codes (Application functions 2)
5.29	U codes (Customizable logic functions)
5.34	U1 codes (Customizable logic functions)
5.35	y codes (Link functions).....
5.36	T codes (Timer functions).....
5.37	K codes (Keypad functions)
5.39	o codes (Option functions)

5.1 Overview of Function Codes

Function codes enable the IMO VXA series of inverters to be set up to match your system requirements.

The function codes are classified into these groups: Fundamental Functions (F codes), Extension Terminal Functions (E codes), Control Functions (C codes), Motor 1 Parameters (P codes), High Performance Functions (H and H1 codes), Application Functions 1 (J codes), PID Control 1 (J1 codes), PID Control 2 (J2 codes), Pump APP Functions (J4 codes), External PID Control 1 (J5 codes), External PID Control 2 and 3 (J6 codes), Application Functions 2 (d codes), Customizable Logic Functions (U and U1 codes), Link Functions (y codes), Timer Operation Functions (T codes), Keypad Functions (K codes), and Option Functions (o codes). To determine the property of each function code, set data to the function code.

This manual does not contain the descriptions of Option Functions (o codes). For o codes, refer to the instruction manual for each option.

5.2 Function Code Tables

The following descriptions supplement those given in the function code tables on page 5-3 and subsequent pages.

■ Changing, validating, and saving function code data when the inverter is running

Function codes are indicated by the following based on whether they can be changed or not when the inverter is running:

Notation	Change when running	Validating and saving function code data
Y*	Possible	If the data of the codes marked with Y* is changed with \uparrow / \downarrow / \leftarrow / \rightarrow keys, the change will immediately take effect; however, the change is not saved into the inverter's memory. To save the change, press the SET key. If you press the STOP key without pressing the SET key to exit the current state, then the changed data will be discarded and the previous data will take effect for the inverter operation.
Y	Possible	Even if the data of the codes marked with Y is changed with \uparrow / \downarrow / \leftarrow / \rightarrow keys, the change will not take effect. Pressing the SET key will make the change take effect and save it into the inverter's memory.
N	Impossible	—

■ Copying data

The keypad is capable of copying the function code data stored in the inverter's memory into the keypad's memory ($\text{PRG} > 2(\text{Function Code}) > 4(\text{Data Copy})$). With this feature, you can easily transfer the data saved in a source inverter to other destination inverters.

If the specifications of the source and destination inverters differ, some code data may not be copied to ensure safe operation of your power system. Whether data will be copied or not is detailed with the following symbols in the "Data copying" column of the function code tables given on page 6-3 and subsequent pages.

Y: Will be copied unconditionally.

Y1: Will not be copied if the rated capacity differs from the source inverter.

N: Will not be copied. (The function code marked with "N" is not subject to the Verify operation, either.)

■ Using negative logic for programmable I/O terminals

The negative logic signaling system can be used for the programmable, digital input and output terminals by setting the function code data specifying the properties for those terminals. Negative logic refers to the inverted ON/OFF (logical value 1 (true)/0 (false)) state of input or output signal. An active-ON signal (the function takes effect if the terminal is short-circuited.) in the normal logic system is functionally equivalent to active-OFF signal (the function takes effect if the terminal is opened.) in the negative logic system. Active-ON signals can be switched to active-OFF signals, and vice versa, with the function code data setting, except some signals.

To set the negative logic system for an input or output terminal, enter data of 1000s (by adding 1000 to the data for the normal logic) in the corresponding function code.

Example: "Coast to a stop" command **BX** assigned to any of digital input terminals [X1] to [X7] using any of function codes E01 through E07.

Function code data	Description
7	Turning BX ON causes the motor to coast to a stop. (Active-ON)
1007	Turning BX OFF causes the motor to coast to a stop. (Active-OFF)

5.3 List of Function Codes

The following tables list the function codes available for the IMO VXA series of inverters.

F codes: Fundamental Functions

Code	Name	Data setting range	Change when running	Data copying	Default setting
F00	Data Protection	0: Disable both data protection and digital reference protection 1: Enable data protection and disable digital reference protection 2: Disable data protection and enable digital reference protection 3: Enable both data protection and digital reference protection	Y	Y	0
F01	Frequency Command 1	0: keys on keypad 1: Voltage input to terminal [12] (-10 to +10 VDC) 2: Current input to terminal [C1] (4 to 20 mA DC) 3: Sum of voltage and current inputs to terminals [12] and [C1] 5: Voltage input to terminal [V2] (0 to 10 VDC) 7: Terminal command UP/DOWN control 8: keys on keypad (balanceless-bumpless switching available) 10: Pattern operation	N	Y	0
F02	Operation Method	0: FWD/REV/STOP keys on keypad (Motor rotational direction specified by terminal command FWD/REV) 1: External signals (Terminal command FWD or REV) 2: FWD/STOP keys on keypad (forward) 3: REV/STOP keys on keypad (reverse)	N	Y	0
F03	Maximum Frequency 1	25.0 to 120.0 Hz	N	Y	50.0
F04	Base Frequency 1	25.0 to 120.0 Hz	N	Y	50.0
F05	Rated Voltage at Base Frequency 1	0: Output a voltage in proportion to input voltage 160 to 500 V: Output an AVR-controlled voltage	N	Y	E: 400 A: 415 C: 380
F06	Maximum Output Voltage 1	160 to 500 V: Output an AVR-controlled voltage	N	Y	
F07	Acceleration Time 1	0.00 to 3600.00 s	Y	Y	20.00
F08	Deceleration Time 1	Note: Entering 0.00 cancels the acceleration time, requiring external soft-start.	Y	Y	20.00
F09	Torque Boost 1	0.0% to 20.0% (percentage with respect to "F05: Rated Voltage at Base Frequency 1")	Y	Y	*1
F10	Electronic Thermal Overload Protection for Motor 1 (Select motor characteristics)	1: For a general-purpose motor with shaft-driven cooling fan 2: For an inverter-driven motor, non-ventilated motor, or motor with separately powered cooling fan	Y	Y	1
F11	(Overload detection level)	OFF: Disable 1% to 135% of the inverter rated current	Y	Y1	*3
F12	(Thermal time constant)	0.5 to 75.0 min	Y	Y	*2
F14	Restart Mode after Momentary Power Failure (Mode selection)	0: Trip immediately 1: Trip after a recovery from power failure 3: Continue to run, for heavy inertia or general loads 4: Restart at the frequency at which the power failure occurred, for general loads 5: Restart at the starting frequency	Y	Y	E: 0 A/C: 1
F15	Frequency Limiter (High)	0.0 to 120.0 Hz	Y	Y	70.0
F16	(Low)	0.0 to 120.0 Hz	Y	Y	0.0
F18	Bias (Frequency command 1)	-100.00% to 100.00%	Y*	Y	0.00
F20	DC Braking 1 (Braking starting frequency)	0.0 to 60.0 Hz	Y	Y	0.0
F21	(Braking level)	0% to 60% on the basis of inverter rated current	Y	Y	0
F22	(Braking time)	OFF (Disable); 0.01 to 30.00 s	Y	Y	OFF
F23	Starting Frequency 1	0.1 to 60.0 Hz	Y	Y	0.5
F24	(Holding time)	0.00 to 10.00 s	Y	Y	0.00
F25	Stop Frequency	0.1 to 60.0 Hz	Y	Y	0.2
F26	Motor Sound (Carrier frequency)	0.75 to 16 kHz (0.75 to 37 kW) 0.75 to 10 kHz (45 to 90 kW) 0.75 to 6 kHz (110 to 630 kW) 0.75 to 4 kHz (710 kW)	Y	Y	2
F27	(Tone)	0: Level 0 (Inactive) 1: Level 1 2: Level 2 3: Level 3	Y	Y	0
F29	Analog Output [FM1] (Mode selection)	0: Output in voltage (0 to 10 VDC) 1: Output in current (4 to 20 mA DC) 2: Output in current (0 to 20 mA DC)	Y	Y	0
F30	(Voltage adjustment)	0% to 300%	Y*	Y	100

The shaded function codes () are applicable to the quick setup.

*1 The factory default differs depending upon the inverter's capacity. See Table A.

*2 5.0 min for inverters with a capacity of 22 kW or below; 10.0 min for those with 30 kW or above

*3 The motor rated current is automatically set. See Table B (function code P03).

Code	Name	Data setting range	Change when running	Data copying	Default setting
F31	Analog Output [FM1] (Function)	Select a function to be monitored from the followings. 0: Output frequency 1 (before slip compensation) 1: Output frequency 2 (after slip compensation) 2: Output current 3: Output voltage 4: Output torque 5: Load factor 6: Input power 7: PID feedback amount 9: DC link bus voltage 10: Universal AO 13: Motor output 14: Calibration (+) 15: PID command (SV) 16: PID output (MV) 18: Inverter heat sink temperature (200°C/10 V) 20: Reference frequency 50: PID feedback amount 1 (PV1) 51: PID command 1 (SV1) 52: PID deviation 1 (ERR1) (Note 1) 53: PID final deviation (ERR) (Note 1) 54: PID feedback amount 2 (PV2) 55: PID command 2 (SV2) 56: PID deviation 2 (ERR2) (Note 1) 60: External PID feedback amount 1 (EPID1-PV) 61: External PID command 1 (EPID1-SV) 62: External PID deviation 1 (EPID1-ERR) (Note 1) 63: External PID final deviation 1 (EPID-ERR) (Note 1) 65: External PID final output 1 (EPID1-OUT) 70: External PID feedback amount 2 (EPID2-PV) 71: External PID command 2 (EPID2-SV) 72: External PID deviation 2 (EPID2-ERR) (Note 1) 75: External PID final output 2 (EPID2-OUT) 80: External PID feedback amount 3 (EPID3-PV) 81: External PID command 3 (EPID3-SV) 82: External PID deviation 3 (EPID3-ERR) (Note 1) 85: External PID final output 3 (EPID3-OUT) 111: Customizable logic output signal 1 112: Customizable logic output signal 2 113: Customizable logic output signal 3 114: Customizable logic output signal 4 115: Customizable logic output signal 5 116: Customizable logic output signal 6 117: Customizable logic output signal 7 (Note 1) Deviation output is supported only by option terminal [Ao] (o09).	Y	Y	0
F32	Pulse Output [FM2] (Mode selection)	0: Voltage (0 to +10 VDC) 1: Current (4 to +20 mA DC) 2: Current (0 to +20 mA DC)	Y	Y	0
F34	(Voltage adjustment)	0 to 300%	Y*	Y	0
F35	(Function)	Same as F31.	Y	Y	0
F37	Load Selection/ Auto Torque Boost/ Auto Energy Saving Operation 1	0: Variable torque load 1: Constant torque load 2: Auto torque boost 3: Auto energy saving (Variable torque load during ACC/DEC) 4: Auto energy saving (Constant torque load during ACC/DEC) 5: Auto energy saving (Auto torque boost during ACC/DEC)	N	Y	1
F40	Torque Limiter 1 (Driving)	OFF: Disable	Y	Y	OFF
F41	(Braking)	20% to 150%: Torque limiter level			
F42	Drive Control Selection 1	0: V/f control with slip compensation inactive 1: Dynamic torque vector control 2: V/f control with slip compensation active	N	Y	0
F43	Current Limiter (Mode selection)	0: Disable (No current limiter works.) 1: Enable at constant speed (Disable during ACC/DEC) 2: Enable during ACC/constant speed operation	Y	Y	2
F44	(Level)	20% to 120% (Assuming the inverter rated current as 100%.)	Y	Y	120

E codes: Extension Terminal Functions

Code	Name	Data setting range	Change when running	Data copying	Default setting
E01	Terminal [X1] Function	Selecting function code data assigns the corresponding function to terminals [X1] to [X7] as listed below.	N	Y	0
E02	Terminal [X2] Function	0 (1000): Select multistep frequency (0 to 1 steps) (SS1)	N	Y	1
E03	Terminal [X3] Function	1 (1001): Select multistep frequency (0 to 3 steps) (SS2)	N	Y	6
E04	Terminal [X4] Function	2 (1002): Select multistep frequency (0 to 7 steps) (SS4)	N	Y	7
E05	Terminal [X5] Function	3 (1003): Select multistep frequency (0 to 15 steps) (SS8)	N	Y	8
E06	Terminal [X6] Function	4 (1004): Select ACC/DEC time (2 steps) (RT1)	N	Y	11
E07	Terminal [X7] Function	5 (1005): Select ACC/DEC time (4 steps) (RT2)	N	Y	35
		6 (1006): Enable 3-wire operation (HLD)			
		7 (1007): Coast to a stop (BX)			
		8 (1008): Reset alarm (RST)			
		9 (1009): Enable external alarm trip (THR) (9 = Active OFF, 1009 = Active ON)			
		11 (1011): Select frequency command 2/1 (Hz2/Hz1)			
		13: Enable DC braking (DCBRK)			
		14 (1014): Select torque limiter level 2/1 (TL2/TL1)			
		15: Switch to commercial power (50 Hz) (SW50)			
		16: Switch to commercial power (60 Hz) (SW60)			
		17 (1017): UP (Increase output frequency) (UP)			
		18 (1018): DOWN (Decrease output frequency) (DOWN)			
		19 (1019): Enable data change with keypad (WE-KP)			
		20 (1020): Cancel PID control (Hz/PID)			
		21 (1021): Switch normal/inverse operation (IVS)			
		22 (1022): Interlock (IL)			
		24 (1024): Enable communications link via RS-485 or fieldbus (option) (LE)			
		25 (1025): Universal DI (U-DI)			
		26 (1026): Enable auto search for idling motor speed at starting (STM)			
		30 (1030): Force to stop (STOP) (30 = Active OFF, 1030 = Active ON)			
		33 (1033): Reset PID integral and differential components (PID-RST)			
		34 (1034): Hold PID integral component (PID-HLD)			
		35 (1035): Select local (keypad) operation (LOC)			
		38 (1038): Enable run commands (RE)			
		39: Protect motor from dew condensation (DWP)			
		40: Enable integrated sequence to switch to commercial power (50 Hz) (ISW50)			
		41: Enable integrated sequence to switch to commercial power (60 Hz) (ISW60)			
		50 (1050): Clear running motor regular switching time (MCLR)			
		58 (1058): Reset UP/DOWN frequency (STZ)			
		72 (1072): Count the run time of commercial power-driven motor 1 (CRUN-M1)			
		80 (1080): Cancel customizable logic (CLC)			
		81 (1081): Clear all customizable logic timers (CLTC)			
		87 (1087): Run command 2/1 (FR2/FR1)			
		88: Run forward 2 (FWD2)			
		89: Run reverse 2 (REV2)			
		100: No function assigned (NONE)			
		130 (1130): Boost command (BST)			
		131 (1131): Flowrate switch (FS)			
		132 (1132): Filter clogging reverse rotation command (FRC)			
		133 (1133): Switch PID channel (PID2/1)			
		134: Switch to fire mode (FMS)			
		149 (1149): Switch pump control (PCHG)			
		150 (1150): Enable master motor drive in mutual operation (MENO)			
		151 (1151): Enable pump control motor 1 to be driven (MEN1)			
		152 (1152): Enable pump control motor 2 to be driven (MEN2)			
		153 (1153): Enable pump control motor 3 to be driven (MEN3)			
		154 (1154): Enable pump control motor 4 to be driven (MEN4)			
		155 (1155): Enable pump control motor 5 to be driven (MEN5)			
		156 (1156): Enable pump control motor 6 to be driven (MEN6)			
		157 (1157): Enable pump control motor 7 to be driven (MEN7)			
		158 (1158): Enable pump control motor 8 to be driven (MEN8)			
		171 (1171): PID multistep command 1 (PID-SS1)			
		172 (1172): PID multistep command 2 (PID-SS2)			
		181 (1181): External PID multistep command (EPID-SS1)			
		182 (1182): External PID multistep command (EPID-SS2)			

Code	Name	Data setting range	Change when running	Data copying	Default setting
		190 (1190): Cancel timer (TMC) 191 (1191): Enable timer 1 (TM1) 192 (1192): Enable timer 2 (TM2) 193 (1193): Enable timer 3 (TM3) 194 (1194): Enable timer 4 (TM4) 201 (1201): External PID control 1 ON command (EPID1-ON) 202 (1202): Cancel external PID control 1 (%/EPID1) 203 (1203): Switch normal/inverse operation under external PID control 1 (EPID1-IVS) 204 (1204): Reset external PID1 integral and differential components (EPID1-RST) 205 (1205): Hold external PID1 integral component (EPID1-HLD) 211 (1211): External PID control 2 ON command (EPID2-ON) 212 (1212): Cancel external PID control 2 (%/EPID2) 213 (1213): Switch normal/inverse operation under external PID control 2 (EPID2-IVS) 214 (1214): Reset external PID2 integral and differential components (EPID2-RST) 215 (1215): Hold external PID2 integral component (EPID2-HLD) 221 (1221): External PID control 3 ON command (EPID3-ON) 222 (1222): Cancel external PID control 3 (%/EPID3) 223 (1223): Switch normal/inverse operation under external PID control 3 (EPID3-IVS) 224 (1224): Reset external PID3 integral and differential components (EPID3-RST) 225 (1225): Hold external PID3 integral component (EPID3-HLD) Setting the value in parentheses () shown above assigns a negative logic output to a terminal. (True if OFF.) Setting the value of 1000s in parentheses () shown above assigns a negative logic input to a terminal.			
E10	Acceleration Time 2	0.00 to 3600.00 s	Y	Y	20.00
E11	Deceleration Time 2	Note: Entering 0.00 cancels the acceleration time, requiring external soft-start and -stop.	Y	Y	20.00
E12	Acceleration Time 3		Y	Y	20.00
E13	Deceleration Time 3		Y	Y	20.00
E14	Acceleration Time 4		Y	Y	20.00
E15	Deceleration Time 4		Y	Y	20.00
E16	Torque Limiter 2 (Driving)		OFF: Disable	Y	Y
E17	(Braking)	20% to 150%: Torque limiter level	Y	Y	OFF
E20	Terminal [Y1] Function	Selecting function code data assigns the corresponding function to terminals [Y1] to [Y5A/C] and [30A/B/C] as listed below.	N	Y	0
E21	Terminal [Y2] Function	0 (1000): Inverter running (RUN)	N	Y	1
E22	Terminal [Y3] Function	1 (1001): Frequency (speed) arrival signal (FAR)	N	Y	2
E23	Terminal [Y4] Function	2 (1002): Frequency (speed) detected (FDT)	N	Y	7
E24	Terminal [Y5A/C] Function	3 (1003): Undervoltage detected (Inverter stopped) (LV)	N	Y	15
E27	Terminal [30A/B/C] Function (Relay output)	5 (1005): Inverter output limiting (IOL)	N	Y	99
		6 (1006): Auto-restarting after momentary power failure (IPF)			
		7 (1007): Motor overload early warning (OL)			
		10 (1010): Inverter ready to run (RDY)			
		11: Switch motor drive source between commercial power and inverter output (For MC on commercial line) (SW88)			
		12: Switch motor drive source between commercial power and inverter output (For secondary side) (SW52-2)			
		13: Switch motor drive source between commercial power and inverter output (For primary side) (SW52-1)			
		15 (1015): Select AX terminal function (For MC on primary side) (AX)			
		16 (1016): Shifted to pattern operation stage (TU)			
		17 (1017): Pattern operation cycle completed (TO)			
		18 (1018): Pattern operation stage number (STG1)			
		19 (1019): Pattern operation stage number (STG2)			
		20 (1020): Pattern operation stage number (STG4)			
		22 (1022): Inverter output limiting with delay (IOL2)			
		25 (1025): Cooling fan in operation (FAN)			
		26 (1026): Auto-resetting (TRY)			
		27 (1027): Universal DO (U-DO)			
		28 (1028): Heat sink overheat early warning (OH)			
		30 (1030): Lifetime alarm (LIFE)			
		31 (1031): Frequency (speed) detected 2 (FDT2)			
		33 (1033): Reference loss detected (REF OFF)			
		35 (1035): Inverter output on (RUN2)			
		36 (1036): Overload prevention control (OLP)			
		37 (1037): Current detected (ID)			
		42 (1042): PID alarm (PID-ALM)			
		43 (1043): Under PID control (PID-CTL)			

Code	Name	Data setting range	Change when running	Data copying	Default setting
		44 (1044): Motor stopped due to slow flowrate under PID control (PID-STP)			
		45 (1045): Low output torque detected (U-TL)			
		52 (1052): Running forward (FRUN)			
		53 (1053): Running reverse (RRUN)			
		54 (1054): In remote operation (RMT)			
		55 (1055): Run command entered (AX2)			
		56 (1056): Motor overheat detected by thermistor (THM)			
		59 (1059): Terminal [C1] wire break (C1OFF)			
		68 (1068): Motor regular switching early warning (MCHG)			
		69 (1069): Pump control output limit signal (MLIM)			
		84 (1084): Maintenance timer (MNT)			
		87(1087): Frequency arrival signal (FARFDT)			
		88(1088): Auxiliary motor drive signal (AUX_L)			
		95(1095): Running in fire mode (FMRUN)			
		98 (1098): Light alarm (L-ALM)			
		99 (1099): Alarm output (for any alarm) (ALM)			
		101(1101): EN terminal detection circuit error (DECF)			
		102(1102): EN terminal OFF (ENOFF)			
		111 (1111): Customizable logic output signal 1 (CLO1)			
		112 (1112): Customizable logic output signal 2 (CLO2)			
		113 (1113): Customizable logic output signal 3 (CLO3)			
		114 (1114): Customizable logic output signal 4 (CLO4)			
		115 (1115): Customizable logic output signal 5 (CLO5)			
		116 (1116): Customizable logic output signal 6 (CLO6)			
		117 (1117): Customizable logic output signal 7 (CLO7)			
		160 (1160): Motor 1 being driven by inverter (M1_I)			
		161 (1161): Motor 1 being driven by commercial power (M1_L)			
		162 (1162): Motor 2 being driven by inverter (M2_I)			
		163 (1163): Motor 2 being driven by commercial power (M2_L)			
		164 (1164): Motor 3 being driven by inverter (M3_I)			
		165 (1165): Motor 3 being driven by commercial power (M3_L)			
		166 (1166): Motor 4 being driven by inverter (M4_I)			
		167 (1167): Motor 4 being driven by commercial power (M4_L)			
		169 (1169): Motor 5 being driven by commercial power (M5_L)			
		171 (1171): Motor 6 being driven by commercial power (M6_L)			
		173 (1173): Motor 7 being driven by commercial power (M7_L)			
		175 (1175): Motor 8 being driven by commercial power (M8_L)			
		180 (1180): In mutual operation (M-RUN)			
		181 (1181): Alarm in mutual operation (M-ALM)			
		190 (1190): In timer operation (TMD)			
		191 (1191): Timer 1 enabled (TMD1)			
		192 (1192): Timer 2 enabled (TMD2)			
		193 (1193): Timer 3 enabled (TMD3)			
		194 (1194): Timer 4 enabled (TMD4)			
		200 (1200): Under PID2 control (PID2)			
		201 (1201): PID1 alarm (PV1-ALM)			
		202 (1202): PID1 feedback error (PV1-OFF)			
		203 (1203): PID2 alarm (PV2-ALM)			
		204 (1204): PID2 feedback error (PV2-OFF)			
		211 (1211): Under external PID1 control (EPID1-CTL)			
		212 (1212): External PID1 output (EPID1-OUT)			
		213 (1213): Running under external PID1 (EPID1-RUN)			
		214 (1214): External PID1 alarm (EPV1-ALM)			
		215 (1215): External PID1 feedback error (EPV1-OFF)			
		221 (1221): Under external PID2 control (EPID2-CTL)			
		222 (1222): External PID2 output (EPID2-OUT)			
		223 (1223): Running under external PID2 (EPID2-RUN)			
		224 (1224): External PID2 alarm (EPV2-ALM)			
		225 (1225): External PID2 feedback error (EPV2-OFF)			
		231 (1231): Under external PID3 control (EPID3-CTL)			
		232 (1232): External PID3 output (EPID3-OUT)			
		233 (1233): Running under external PID3 (EPID3-RUN)			
		234 (1234): External PID3 alarm (EPV3-ALM)			
		235 (1235): External PID3 feedback error (EPV3-OFF)			
		Setting the value in parentheses () shown above assigns a negative logic output to a terminal. (True if OFF.)			
		Setting the value of 1000s in parentheses () shown above assigns a negative logic input to a terminal.			

Code	Name	Data setting range	Change when running	Data copying	Default setting
E30	Frequency Arrival (Hysteresis width)	0.0 to 10.0 Hz	Y	Y	2.5
E31	Frequency Detection 1 (Level)	0.0 to 120.0 Hz	Y	Y	50.0
E32	(Hysteresis width)	0.0 to 120.0 Hz	Y	Y	1.0
E34	Overload Early Warning/Current Detection (Level)	OFF: Disable 1 to 150% of inverter rated current	Y	Y1	*3
E35	(Timer)	0.01 to 600.00s	Y	Y	10.00
E61	Terminal [12] Extended Function	0: None	N	Y	0
E62	Terminal [C1] Extended Function	1: Auxiliary frequency command 1	N	Y	0
E63	Terminal [V2] Extended Function	2: Auxiliary frequency command 2 3: PID process command 1 4: PID process command 2 5: PID feedback value 1 12: Acceleration/deceleration time ratio setting 13: Upper limit frequency 14: Lower limit frequency 20: Analog signal input monitor 30: PID feedback value 2 31: Auxiliary input 1 to PID process command 32: Auxiliary input 2 to PID process command 33: Flow sensor 41: External PID process command 1 42: External PID feedback value 1 43: External PID manual command 1 44: External PID process command 2 45: External PID feedback value 2 46: External PID manual command 2 47: External PID process command 3 48: External PID feedback value 3 49: External PID manual command 3	N	Y	0
E64	Saving of Digital Reference Frequency	0: Automatic saving (when main power is turned OFF) 1: Saving by pressing  key	Y	Y	1
E65	Reference Loss Detection (Continuous running frequency)	OFF: Cancel Decel: Decelerate to stop 20% to 120%	Y	Y	OFF
E80	Low Torque Detection (Level)	0% to 150%	Y	Y	20
E81	(Timer)	0.01 to 600.00 s	Y	Y	20.00
E82	Switching Frequency of Accel/Decel Time in Low-Speed Domain	Inherit: Follow the setting of F16 0.1 to 120.0 Hz	Y	Y	Inherit
E83	Acceleration Time in Low-Speed Domain	Inherit: Follow the current acceleration time 0.01 to 3600.00 s: Acceleration time from 0 Hz to E82	Y	Y	Inherit
E84	Deceleration Time in Low-Speed Domain	Inherit: Follow the current deceleration time 0.01 to 3600.00 s: Deceleration time from E82 to 0 Hz	Y	Y	Inherit
E85	Gradual Deceleration Time Switching Frequency	OFF: Disable 0.1 to 120.0 Hz	Y	Y	OFF
E86	Gradual Deceleration Time (Check valve protection)	Inherit: Follow the current deceleration time 0.01 to 3600.00 s: Deceleration time from E82 to E85	Y	Y	Inherit

*3 The motor parameters are set by capacities. See Table B (function code P03).

Code	Name	Data setting range	Change when running	Data copying	Default setting
E98	Terminal [FWD] Function	0 (1000): Select multistep frequency (0 to 1 steps) (SS1)	N	Y	98
E99	Terminal [REV] Function	1 (1001): Select multistep frequency (0 to 3 steps) (SS2)	N	Y	99
		2 (1002): Select multistep frequency (0 to 7 steps) (SS4)			
		3 (1003): Select multistep frequency (0 to 15 steps) (SS8)			
		4 (1004): Select ACC/DEC time (2 steps) (RT1)			
		5 (1005): Select ACC/DEC time (4 steps) (RT2)			
		6 (1006): Enable 3-wire operation (HLD)			
		7 (1007): Coast to a stop (BX)			
		8 (1008): Reset alarm (RST)			
		9 (1009): Enable external alarm trip (THR) (9 = Active OFF, 1009 = Active ON)			
		11 (1011): Select frequency command 2/1 (Hz2/Hz1)			
		13: Enable DC braking (DCBRK)			
		14 (1014): Select torque limiter level 2/1 (TL2/TL1)			
		15: Switch to commercial power (50 Hz) (SW50)			
		16: Switch to commercial power (60 Hz) (SW60)			
		17 (1017): UP (Increase output frequency) (UP)			
		18 (1018): DOWN (Decrease output frequency) (DOWN)			
		19 (1019): Enable data change with keypad (WE-KP)			
		20 (1020): Cancel PID control (Hz/PID)			
		21 (1021): Switch normal/inverse operation (IVS)			
		22 (1022): Interlock (IL)			
		24 (1024): Enable communications link via RS-485 or fieldbus (LE)			
		25 (1025): Universal DI (U-DI)			
		26 (1026): Enable auto search for idling motor speed at starting (STM)			
		30 (1030): Force to stop (STOP) (30 = Active OFF, 1030 = Active ON)			
		33 (1033): Reset PID integral and differential components (PID-RST)			
		34 (1034): Hold PID integral component (PID-HLD)			
		35 (1035): Select local (keypad) operation (LOC)			
		38 (1038): Enable run commands (RE)			
		39: Protect motor from dew condensation (DWVP)			
		40: Enable integrated sequence to switch to commercial power (50 Hz) (ISW50)			
		41: Enable integrated sequence to switch to commercial power (60 Hz) (ISW60)			
		50 (1050): Clear running motor regular switching time (MCLR)			
		58 (1058): Reset UP/DOWN frequency (STZ)			
		72 (1072): Count the run time of commercial power-driven motor 1 (CRUN-M1)			
		80 (1080): Cancel customizable logic (CLC)			
		81 (1081): Clear all customizable logic timers (CLTC)			
		87 (1087): Run command 2/1 (FR2/FR1)			
		88: Run forward 2 (FWD2)			
		89: Run reverse 2 (REV2)			
		98: Run forward (FWD)			
		99: Run reverse (REV)			
		100: No function assigned (NONE)			
		130 (1130): Boost command (BST)			
		131 (1131): Flowrate switch (FS)			
		132 (1132): Filter clogging reverse rotation command (FRC)			
		133 (1133): Switch PID channel (PID2/1)			
		134: Switch to fire mode (FMS)			
		149 (1149): Switch pump control (PCHG)			
		150 (1150): Enable master motor drive in mutual operation (MENO)			
		151 (1151): Pump control motor 1 (MEN1)			
		152 (1152): Pump control motor 2 (MEN2)			
		153 (1153): Pump control motor 3 (MEN3)			
		154 (1154): Pump control motor 4 (MEN4)			
		155 (1155): Pump control motor 5 (MEN5)			
		156 (1156): Pump control motor 6 (MEN6)			
		157 (1157): Pump control motor 7 (MEN7)			
		158 (1158): Pump control motor 8 (MEN8)			
		171 (1171): PID multistep command (PID-SS1)			
		172 (1172): PID multistep command (PID-SS2)			
		181 (1181): External PID multistep command (EPID-SS1)			
		182 (1182): External PID multistep command (EPID-SS2)			

Code	Name	Data setting range	Change when running	Data copying	Default setting
		190 (1190): Cancel timer (TMC) 191 (1191): Enable timer 1 (TM1) 192 (1192): Enable timer 2 (TM2) 193 (1193): Enable timer 3 (TM3) 194 (1194): Enable timer 4 (TM4) 201 (1201): External PID control 1 ON command (EPID1-ON) 202 (1202): Cancel external PID control 1 (%/EPID1) 203 (1203): Switch normal/inverse operation under external PID control 1 (EPID1-IVS) 204 (1204): Reset external PID1 integral and differential components (EPID1-RST) 205 (1205): Hold external PID1 integral component (EPID1-HLD) 211 (1211): External PID control 2 ON command (EPID2-ON) 212 (1212): Cancel external PID control 2 (%/EPID2) 213 (1213): Switch normal/inverse operation under external PID control 2 (EPID2-IVS) 214 (1214): Reset external PID2 integral and differential components (EPID2-RST) 215 (1215): Hold external PID2 integral component (EPID2-HLD) 221 (1221): External PID control 3 ON command (EPID3-ON) 222 (1222): Cancel external PID control 3 (%/EPID3) 223 (1223): Switch normal/inverse operation under external PID control 3 (EPID3-IVS) 224 (1224): Reset external PID3 integral and differential components (EPID3-RST) 225 (1225): Hold external PID3 integral component (EPID3-HLD) Setting the value in parentheses () shown above assigns a negative logic output to a terminal. (True if OFF.) Setting the value of 1000s in parentheses () shown above assigns a negative logic input to a terminal.			

C codes: Control Functions of Frequency

Code	Name	Data setting range	Change when running	Data copying	Default setting
C01	Jump Frequency 1	0.0 to 120.0 Hz	Y	Y	0.0
C02	2		Y	Y	0.0
C03	3		Y	Y	0.0
C04	(Hysteresis width)		0.0 to 30.0 Hz	Y	Y
C05	Multistep Frequency 1	0.00 to 120.00 Hz	Y	Y	0.00
C06	2		Y	Y	0.00
C07	3		Y	Y	0.00
C08	4		Y	Y	0.00
C09	5		Y	Y	0.00
C10	6		Y	Y	0.00
C11	7		Y	Y	0.00
C12	8		Y	Y	0.00
C13	9		Y	Y	0.00
C14	10		Y	Y	0.00
C15	11		Y	Y	0.00
C16	12		Y	Y	0.00
C17	13		Y	Y	0.00
C18	14		Y	Y	0.00
C19	15		Y	Y	0.00
C21	Pattern Operation (Mode selection)	0: Carry out a single cycle of the specified pattern operation and stop the inverter output 1: Carry out the specified pattern operation repeatedly and stop the inverter output upon receipt of a stop command. 2: Carry out a single cycle of the specified pattern operation and continue to run at the last reference frequency.	N	Y	0
C22	Pattern Operation (Stage 1)	0.00 to 6000.00 s FWD/RED 1 to 4	Y	Y	0.00 FWD 1
C23	(Stage 2)				
C24	(Stage 3)				
C25	(Stage 4)				
C26	(Stage 5)				
C27	(Stage 6)				
C28	(Stage 7)				
C30	Frequency Command 2	0: Enable \triangleleft / \triangleright keys on the keypad 1: Voltage input to terminal [12] (-10 to +10 VDC) 2: Current input to terminal [C1] (4 to 20 mA DC) 3: Sum of voltage and current inputs to terminals [12] and [C1] 5: Voltage input to terminal [V2] (0 to 10 VDC) 7: Terminal command UP/DOWN control 8: Enable \triangleleft / \triangleright keys on the keypad (balanceless-bumpless switching available) 10: Pattern operation	N	Y	2
C31	Analog Input Adjustment for [12] (Offset)	-5.0% to 5.0%	Y*	Y	0.0
C32	(Gain)	0.00% to 200.00%	Y*	Y	100.00
C33	(Filter time constant)	0.00 to 5.00 s	Y	Y	0.05
C34	(Gain base point)	0.00% to 100.00%	Y*	Y	100.00
C35	(Polarity)	0: Bipolar 1: Unipolar	N	Y	1
C36	Analog Input Adjustment for [C1] (Offset)	-5.0% to 5.0%	Y*	Y	0.0
C37	(Gain)	0.00% to 200.00%	Y*	Y	100.00
C38	(Filter time constant)	0.00 to 5.00s	Y	Y	0.05
C39	(Gain base point)	0.00% to 100.00%	Y*	Y	100.00
C40	Terminal [C1] Input Range Selection	0: 4 to 20 mA 1: 0 to 20 mA	N	Y	0
C41	Analog Input Adjustment for [V2] (Offset)	-5.0% to 5.0%	Y*	Y	0.0
C42	(Gain)	0.00% to 200.00%	Y*	Y	100.00
C43	(Filter time constant)	0.00 to 5.00 s	Y	Y	0.05
C44	(Gain base point)	0.00% to 100.00%	Y*	Y	100.00
C45	(Polarity)	0: Bipolar 1: Unipolar	N	Y	1
C53	Selection of Normal/Inverse Operation (Frequency command 1)	0: Normal operation 1: Inverse operation	Y	Y	0
C55	Analog Input Adjustment for Terminal [12] (Bias value)	-100.00 to 100.00%	Y	Y	0.00
C56	(Bias base point)	0.00 to 100.00%	Y	Y	0.00

Code	Name	Data setting range	Change when running	Data copying	Default setting
C58	Analog Input Adjustment for Terminal [12] (Display unit)	1: none 2: % 4: r/min 7: kW <u>Flowrate</u> 20: m ³ /s 21: m ³ /min 22: m ³ /h 23: L/s 24: L/min 25: L/h <u>Pressure</u> 40: Pa 41: kPa 42: MPa 43: mbar 44: bar 45: mmHg 46: psi (Pound per square inch) 47: mWG 48: inWG <u>Temperature</u> 60: K 61: °C 62: °F <u>Density</u> 80: ppm	Y	Y	2
C59	(Maximum scale)	-999.00 to 0.00 to 9990.00	N	Y	100
C60	(Minimum scale)	-999.00 to 0.00 to 9990.00	N	Y	0.00
C61	Analog Input Adjustment for Terminal [C1] (Bias value)	-100.00 to 100.00%	Y	Y	0.00
C62	(Bias base point)	0.00 to 100.00%	Y	Y	0.00
C64	(Display unit)	Same as C58.	Y	Y	2
C65	(Maximum scale)	-999.00 to 0.00 to 9990.00	N	Y	100
C66	(Minimum scale)	-999.00 to 0.00 to 9990.00	N	Y	0.00
C67	Analog Input Adjustment for Terminal [V2] (Bias value)	-100.00 to 100.00%	Y	Y	0.00
C68	(Bias base point)	0.00 to 100.00%	Y	Y	0.00
C70	(Display unit)	Same as C58.	Y	Y	2
C71	(Maximum scale)	-999.00 to 0.00 to 9990.00	N	Y	100
C72	(Minimum scale)	-999.00 to 0.00 to 9990.00	N	Y	0.00

Note: Alphabets in the Default setting field denote shipping destination: E (EU), A (Asia), C (China).

P codes: Motor 1 Parameters

Code	Name	Data setting range	Change when running	Data copying	Default setting
P01	Motor 1 (No. of poles)	2 to 22 poles	N	Y1	4
P02	(Rated capacity)	0.01 to 1000.00 kW (when P99 = 0 or 4) 0.01 to 1000.00 HP (when P99 = 1)	N	Y1	*6
P03	(Rated current)	0.00 to 2000.00 A	N	Y1	*6
P04	(Auto-tuning)	0: Disable 1: Tune the motor while it is stopped (%R1, %X) 2: Tune the motor while it is rotating under V/f control (%R1, %X, no-load current)	N	N	0
P05	(Online-tuning)	0: Disable 1: Enable	Y	Y	0
P06	(No-load current)	0.00 to 2000.00 A	N	Y1	*6
P07	(%R1)	0.00% to 50.00%	Y	Y1	*6
P08	(%X)	0.00% to 50.00%	Y	Y1	*6
P10	(Slip compensation response time)	0.01 to 10.00 s	Y	Y1	0.50
P12	(Rated slip frequency)	0.00 to 15.00 Hz	N	Y1	*6
P99	Motor 1 Selection	0: Motor characteristics 0 (Fuji standard motors, 8-series) 1: Motor characteristics 1 (HP rating motors) 4: Other motors	N	Y1	0

The shaded function codes () are applicable to the quick setup.

*6 The motor parameters are automatically set, depending upon the inverter's capacity. See Table B.

H codes: High Performance Functions

Code	Name	Data setting range	Change when running	Data copying	Default setting
H03	Data Initialization	0: Disable initialization 1: Initialize all function code data to factory defaults 2: Initialize motor 1 parameters 10: Initialize real-time clock information 11: Initialize function code data except communication function codes 12: Initialize U code data (Customizable logic function codes) 51: Initialize according to application (Single pump drive) 52: Initialize according to application (Inverter drive motor fixed system for 5 motors) 53: Initialize according to application (Inverter drive motor fixed system for 8 motors) 54: Initialize according to application (Inverter drive motor floating system) 55: Initialize according to application (Inverter drive motor floating + commercial power-driven motor system) 56: Initialize according to application (Communications-linked inverter drive motor floating system for master) 57: Initialize according to application (Communications-linked inverter drive motor floating system for slave 1) 58: Initialize according to application (Communications-linked inverter drive motor floating system for slave 2) 59: Initialize according to application (Compressor 2) 71: Initialize according to application (Compressor) 72: Initialize according to application (Fan)	N	N	0
H04	Auto-reset (Times)	OFF: Disable; 1 to 20	Y	Y	OFF
H05	(Reset interval)	0.5 to 60.0 s	Y	Y	5.0
H06	Cooling Fan ON/OFF Control	0: Disable (Always in operation) 1: Enable (ON/OFF controllable)	Y	Y	1
H07	Acceleration/Deceleration Pattern	0: Linear 1: S-curve (Weak) 2: S-curve (Strong) 3: Curvilinear	Y	Y	0
H08	Rotational Direction Limitation	0: Disable 1: Enable (Reverse rotation inhibited) 2: Enable (Forward rotation inhibited) 3: Enable (Reverse rotation inhibited, setting only) 4: Enable (Forward rotation inhibited, setting only)	N	Y	0
H09	Starting Mode (Auto search)	0: Disable 1: Enable (At restart after momentary power failure) 2: Enable (At restart after momentary power failure and at normal start)	N	Y	0
H11	Deceleration Mode	0: Normal deceleration 1: Coast-to-stop	Y	Y	0
H12	Instantaneous Overcurrent Limiting (Mode selection)	0: Disable 1: Enable	Y	Y	1
H13	Restart Mode after Momentary Power Failure (Restart time)	0.1 to 20.0 s	Y	Y1	*2
H14	(Frequency fall rate)	Inherit: With the selected deceleration time 0.01 to 100.00 Hz/s Auto: With the current limiter	Y	Y	Auto
H15	(Continuous running level)	400 to 600 V	Y	Y1	470
H16	(Allowable momentary power failure time)	0.0 to 30.0 s Auto: Automatically determined by inverter	Y	Y	Auto
H26	Thermistor (for motor) (Mode selection)	0: Disable 1: PTC (The inverter immediately trips with OH4 displayed.) 2: PTC (The inverter issues output signal THM and continues to run.)	Y	Y	0
H27	(Level)	0.00 to 5.00 V	Y	Y	0.35
H30	Communications Link Function (Mode selection)	Frequency command Run command 0: F01/C30 F02 1: RS-485 (Port 1) F02 2: F01/C30 RS-485 (Port 1) 3: RS-485 (Port 1) RS-485 (Port 1) 4: RS-485 (Port 2) F02 5: RS-485 (Port 2) RS-485 (Port 1) 6: F01/C30 RS-485 (Port 2) 7: RS-485 (Port 1) RS-485 (Port 2) 8: RS-485 (Port 2) RS-485 (Port 2)	Y	Y	0
H42	Capacitance of DC Link Bus Capacitor	Meas (Measure initial value), Failed (Measurement failed), 2 to 65535 Indication for replacement of DC link bus capacitor	Y	N	-
H43	Cumulative Run Time of Cooling Fan	Indication for replacement of cooling fan 0 to 99990 (in units of 10 hours)	Y	N	-
H44	Startup Counter for Motor 1	Indication of cumulative startup count 0 to 65535	Y	N	-
H45	Mock Alarm	0: Disable 1: Enable (Once a mock alarm occurs, the data automatically returns to 0.)	Y	N	0

*2 The factory default differs depending upon the inverter's capacity. See Table A.

*6 The motor rated current is automatically set. See Table B.

Code	Name	Data setting range	Change when running	Data copying	Default setting
H46	Starting Mode (Auto search delay time 2)	0.1 to 20.0 s	Y	Y1	*6
H47	Initial Capacitance of DC Link Bus Capacitor	Meas (Measure initial value), Failed (Measurement failed), 2 to 65535 Indication for replacement of DC link bus capacitor	Y	N	-
H48	Cumulative Run Time of Capacitors on Printed Circuit Boards	Indication for replacement of capacitors 0 to 99990 (in units of 10 hours)	Y	N	-
H49	Starting Mode (Auto search delay time 1)	0.0 to 10.0 s	Y	Y	0.0
H50	Non-linear V/f Pattern 1 (Frequency)	OFF: Cancel, 0.1 to 120.0 Hz	N	Y	*7
H51	(Voltage)	0 to 500: Output an AVR-controlled voltage	N	Y1	E/A: *8 C: 0
H52	Non-linear V/f Pattern 2 (Frequency)	OFF: Cancel, 0.1 to 120.0 Hz	N	Y	OFF
H53	(Voltage)	0 to 500: Output an AVR-controlled voltage	N	Y1	0
H56	Deceleration Time for Forced Stop	0.00 to 3600 s	Y	Y	20.0
H61	Multistep Frequency + UP/DOWN Control (Initial frequency setting)	1: Last UP/DOWN command value on releasing the run command 13 to 106: Multistep frequency + UP/DOWN command (Initial value to be preserved)	N	Y	1
H63	Low Limiter (Mode selection)	0: Limit by F16 (Frequency limiter: Low) and continue to run 1: If the output frequency lowers below the one limited by F16 (Frequency limiter: Low), decelerate to stop the motor.	Y	Y	0
H64	(Lower limiting frequency)	Inherit: Depends on F16 (Frequency limiter, Low) 0.1 to 60.0 Hz	Y	Y	2.0
H68	Slip Compensation 1 (Operating conditions)	0: Enable during ACC/DEC and at base frequency or above 1: Disable during ACC/DEC and enable at base frequency or above 2: Enable during ACC/DEC and disable at base frequency or above 3: Disable during ACC/DEC and at base frequency or above	N	Y	0
H69	Automatic Deceleration (Mode selection)	0: Disable 2: Torque limit control with Force-to-stop if actual deceleration time exceeds three times the specified one 3: DC link bus voltage control with Force-to-stop if actual deceleration time exceeds three times the specified one 4: Torque limit control with Force-to-stop disabled 5: DC link bus voltage control with Force-to-stop disabled	Y	Y	0
H70	Overload Prevention Control	OFF: Cancel Inherit: Follow the selected deceleration time 0.01 to 100.00 Hz/s	Y	Y	OFF
H71	Deceleration Characteristics	0: Disable 1: Enable	Y	Y	0
H72	Main Power Down Detection (Mode selection)	0: Disable 1: Enable	Y	Y	1
H76	Torque Limiter for Braking (Frequency increment limit)	0.0 to 120.0 Hz	Y	Y	5.0
H77	Service Life of DC Link Bus Capacitor (Remaining time)	0 to 43800 (in units of 10 hours)	Y	N	-
H78	Maintenance Interval (M1)	OFF: Disable 10 to 99990 (in units of 10 hours)	Y	N	43800
H79	Preset Startup Count for Maintenance (M1)	OFF: Disable 1 to 65535	Y	N	OFF
H80	Output Current Fluctuation Damping Gain for Motor 1	0.00 to 1.00	Y	Y	0.20
H89	Reserved *9	0, 1	Y	Y	1
H90	Reserved *9	0, 1	Y	Y	0
H91	Current Input Wire Break Detection	OFF: Disable, 0.1 to 60.0 s	Y	Y	OFF
H92	Continuity of Running (P)	0.000 to 10.000 times Auto	Y	Y1	Auto
H93	(I)	0.010 to 10.000 s Auto	Y	Y1	Auto
H94	Cumulative Motor Run Time 1	0 to 99990 (The cumulative run time can be modified or reset in units of 10 hours.)	N	N	-
H95	DC Braking (Braking response mode)	0: Slow 1: Quick	Y	Y	1
H96	STOP Key Priority/Start Check Function	Data STOP key priority Start check function 0: Disable Disable 1: Enable Disable 2: Disable Enable 3: Enable Enable	Y	Y	0
H97	Clear Alarm Data	0: Disable 1: Enable (Setting "1" clears alarm data and then returns to "0.")	Y	N	0

Note: Alphabets in the Default setting field denote shipping destination: E (EU), A (Asia), C (China).

*7 0.0 (Cancel) for inverters with a capacity of 22 kW or below; 5.0 Hz for those with 30 kW or above.

*8 0 V for inverters with a capacity of 22 kW or below; 40 V for inverters with 30 kW or above, respectively.

*9 These function codes are reserved for particular manufacturers. Unless otherwise specified, do not access these function codes.

Code	Name	Data setting range	Change when running	Data copying	Default setting
H98	Protection/Maintenance Function (Mode selection)	0 to 255 Bit 0: Lower the carrier frequency automatically (0: Disabled; 1: Enabled) Bit 1: Detect input phase loss (0: Disabled; 1: Enabled) Bit 2: Detect output phase loss (0: Disabled; 1: Enabled) Bit 3: Select life judgment threshold of DC link bus capacitor (0: Factory default level; 1: User setup level) Bit 4: Judge the life of DC link bus capacitor (0: Disabled; 1: Enabled) Bit 5: DC fan lock detection (0: Disabled; 1: Enabled) Bit 7: Switch IP21/IP55 enclosure (0: IP21; 1: IP55)	Y	Y	AQ1M (IP21) 19 AQ1L (IP55) 147
H104	Number-of-retry Clear Time	0.5 to 5.0 (min)	Y	Y	5.0
H105	Retry Target Selection	0 to 255 Bit 0: OC1 to OC3 Bit 1: OV1 to OV3 Bit 2: OH1 OH3 OLU Bit 3: - Bit 4: OL1 Bit 5: OH4 Bit 6: - Bit 7: -	Y	Y	225
H106	Retry Target Selection 2	0 to 255 Bit 0: OH2 Bit 1: LV Bit 2: - Bit 3: - Bit 4: - Bit 5: - Bit 6: - Bit 7: -	Y	Y	0
H110	Input Phase Loss Protection Avoidance Operation (Mode selection)	0: Disable 1: Enable (Decrease output frequency)	Y	Y	0
H112	Voltage Shortage Avoidance Operation (Mode selection)	0: Disable 1: Enable (Decrease output frequency)	Y	Y	0
H114	Automatic Deceleration (Operation level)	0.0 to 50.0% Auto	Y	Y	Auto
H116	Fire Mode (Mode selection)	0: FMS: ON 1: FMS toggle method 2: FMS latch method	N	Y	0
H117	(Confirmation time)	0.5 to 10.0 s * Set ON/OFF setting time for FMS signals.	Y	Y	3.0
H118	(Reference frequency)	Inherit: Follow the ordinary reference frequency specified with F01, etc. 0.1 to 120.0 Hz	Y	Y	Inherit
H119	(Rotation direction)	0: Follow the run command specified with F02, etc. 2: Forward rotation 3: Reverse rotation	N	Y	0
H120	(Start method)	0: Follows the start methods specified with instant power failure restart 1: Auto search	Y	Y	0
H121	(Reset interval)	0.5 to 20.0 s	Y	Y	5.0
H181	Light Alarm Selection 1	0 to 255 Bit 0: - Bit 1: OH2 Bit 2: OH3 Bit 3: - Bit 4: - Bit 5: OL1 Bit 6: - Bit 7: -	Y	Y	0
H182	Light Alarm Selection 2	0 to 255 Bit 0: - Bit 1: - Bit 2: Er4 Bit 3: Er5 Bit 4: Er8 Bit 5: ErP Bit 6: - Bit 7: -	Y	Y	0

Code	Name	Data setting range	Change when running	Data copying	Default setting
H183	Light Alarm Selection 3	0 to 255 Bit 0: - Bit 1: - Bit 2: - Bit 3: CoF, PV1, PV2, PVA, PVb, PVC Bit 4: FAL Bit 5: OL Bit 6: OH Bit 7: LiF	Y	Y	0
H184	Light Alarm Selection 4	0 to 255 Bit 0: rEF Bit 1: PA1, PA2, PAA, PAb, PAC Bit 2: UTL Bit 3: PTC Bit 4: rTE Bit 5: CnT Bit 6: - Bit 7: Lob, dtL	Y	Y	128
H197	User Password 1 (Mode selection)	0: Disclose all function codes but prohibit any change 1: Disclose function codes selected for quick setup only and allow change * This specifies the protection of user password 1.	Y	Y	0

J codes: Application Functions 1

Code	Name	Data setting range	Change when running	Data copying	Default setting
J21	Dew Condensation Prevention (Duty)	1% to 50%	Y	Y	1
J22	Commercial Power Switching Sequence	0: Keep inverter operation (Stop due to alarm) 1: Automatically switch to commercial-power operation	N	Y	0

J1 codes: PID Control 1

Code	Name	Data setting range	Change when running	Data copying	Default setting
J101	PID Control 1 (Mode selection)	0: Disable 1: Enable (Process control, normal operation) 2: Enable (Process control, inverse operation)	N	Y	0
J102	(Command selection)	0: Keypad (△/▽ key) 1: PID command 1 (Analog input: Terminals [12], [C1] and [V2]) 3: UPI/DOWN 4: Command via communications link (Use function code S13)	N	Y	0
J103	(Feedback selection)	1: PID control 1 feedback value 10: Addition (PID control 1 feedback value + PID control 2 feedback value) 11: Difference (PID control 1 feedback value - PID control 2 feedback value) 12: Average (PID control 1 feedback value, PID control 2 feedback value) 13: Maximum (PID control 1 feedback value, PID control 2 feedback value) 14: Minimum (PID control 1 feedback value, PID control 2 feedback value)	N	Y	1
J104	(Deviation selection)	0: (J102)-(J103) 1: Selection of maximum (selection of maximum for PID control 1 and 2 deviation) 2: Selection of minimum (selection of minimum for PID control 1 and 2 deviation)	N	Y	0

Code	Name	Data setting range	Change when running	Data copying	Default setting
J105	PID Control 1 (Display unit)	0: Based on the unit/scale of the PID control 1 feedback amount 1: none 2: % 4: r/min 7: kW <u>Flowrate</u> 20: m ³ /s 21: m ³ /min 22: m ³ /h 23: L/s 24: L/min 25: L/h <u>Pressure</u> 40: Pa 41: kPa 42: MPa 43: mbar 44: bar 45: mmHg 46: psi (Pound per square inch) 47: mWG 48: inWG <u>Temperature</u> 60: K 61: °C 62: °F <u>Density</u> 80: ppm	N	Y	0
J106	(Maximum scale)	-999.00 to 0.00 to 9990.00	N	Y	100
J107	(Minimum scale)	-999.00 to 0.00 to 9990.00	N	Y	0.00
J108	(Tuning)	0: Disable 1: Short-time response 2: Long-time response	Y	Y	0
J109	(Tuning manipulated value)	10 to 100% (Maximum frequency = 100%)	Y	Y	10%
J110	P (Gain)	0.000 to 30.000 times	Y	Y	0.100
J111	I (Integral time)	0.0 to 3600.0 s	Y	Y	0.0
J112	D (Differential time)	0.00 to 600.00 s	Y	Y	0.00
J113	(Feedback filter)	0.0 to 900.0 s	Y	Y	0.5
J114	(Anti-reset wind-up)	OFF: Disable 0.01 to 9990.00 *10	Y	Y	OFF
J118	(Upper limit of PID process output)	0.0 to 120.0 Hz; Inherit (Depends on setting of F15)	Y	Y	Inherit
J119	(Lower limit of PID process output)	0.0 to 120.0 Hz; Inherit (Depends on setting of F16)	Y	Y	Inherit
J121	(Alarm output selection)	0: Absolute-value alarm 1: Absolute-value alarm (with Hold) 2: Absolute-value alarm (with Latch) 3: Absolute-value alarm (with Hold and Latch) 4: Deviation alarm 5: Deviation alarm (with Hold) 6: Deviation alarm (with Latch) 7: Deviation alarm (with Hold and Latch)	Y	Y	0
J122	(Upper level alarm (AH))	-999.00 to 0.00 to 9990.00 *10 OFF	Y	Y	OFF
J124	(Lower level alarm (AL))	-999.00 to 0.00 to 9990.00 *10 OFF	Y	Y	OFF
J127	(Feedback failure detection (Mode selection))	0: Disable (Turns ON output signals (PV1-OFF) and continues operation.) 1: Enable (Free run stop (PV1 trip)) 2: Enable (Deceleration and stop (PV1 trip)) 3: Enable (Continuation of operation at the maximum frequency (upper limit frequency)) 4: Enable (Continuation of operation at the minimum frequency (lower limit frequency)) 5: Enable (Continuation of operation at the frequency used when failure is detected.) 6: Enable (Shift to PID control 2 (PID control 1 is restored when failure is recovered from.))	Y	Y	0

*10 The upper and lower level values are restricted by the maximum and minimum scales.

Code	Name	Data setting range	Change when running	Data copying	Default setting
J128	(Feedback failure continuation duration)	0 to 3600 s; Cont. Cont. (Mode selection: continuation of operation specified with J127. PV1 trip after stop (output shutoff).)	Y	Y	Cont.
J129	(Feedback failure upper-limit)	-999.00 to 0.00 to 9990.00 *10 Auto: 105% equivalent	Y	Y	Auto
J130	(Feedback failure lower-limit)	-999.00 to 0.00 to 9990.00 *10 Auto: -5% equivalent	Y	Y	Auto
J131	(Feedback failure detection time)	0.0 to 300.0 s	Y	Y	0.1
J136	PID Multistep Command (Multistep command 1)	-999.00 to 0.00 to 9990.00	Y	Y	0.00
J137	(Multistep command 2)		Y	Y	0.00
J138	(Multistep command 3)		Y	Y	0.00
J143	Boost Function (Mode selection)	0: Disable (disabled at the time of initiation) 1: Enable ("enabled at the time of initiation" plus "only at the time of PID control") 2: Enable (always enabled at the time of initiation) 3: Enable ("only first initiation with power ON" plus "only at the time of PID control") 4: Enable (only at the time of first initiation with power ON)	Y	Y	0
J144	(Operation frequency)	Inherit: Maximum frequency 0.1 to 120.0 Hz	Y	Y	Inherit
J145	(Acceleration time)	Inherit; 0.01 to 3600 s Inherit: The currently effective acceleration time is followed. * Acceleration time from 0 Hz to Fmax should be specified. * In the case of J145 ≠ 0.00, the acceleration/deceleration time selection function is disabled.	Y	Y	Inherit
J146	(Operation time)	0.0 to 3600.0 s * Specify the time including acceleration time. * 0.0 Time period while the boost command BST is ON (When BST is not used, this is used as the time until the operation frequency is reached.)	Y	Y	0.0
J147	(Cancel PV level)	-999.00 to 0.00 to 9990.00 *10 OFF	Y	Y	OFF
J149	Slow Flowrate Stop Function (Mode selection)	0: Disable (display of OFF) 1: Manual operation (stop judgment: MV) 2: Manual operation (stop judgment: PV) 11: Auto operation 1 (stop judgment: MV): Deviation detection method 12: Auto operation 1 (stop judgment: PV): Deviation detection method 21: Auto operation 2 (stop judgment: MV): Flow sensor detection method 22: Auto operation 2 (stop judgment: PV): Flow sensor detection method	N	Y	OFF
J150	(Operation level)	J149 = MV: 0.00 to 120.00 Hz, Auto J149 = PV: 0.00 to 9990.00, Auto *10	Y	Y	Auto
J151	(Elapsed time)	0 to 60 s	Y	Y	0
J152	(Auto-operation frequency lower-limit)	0.0 to 120.0 Hz	Y		0.0
J153	(Pressurization starting frequency)	0.0 to 120.0 Hz	Y	Y	0.0
J154	(Pressurizing time)	0 to 60 s	Y	Y	0
J156	(Initiation inhibition time)	0 to 3600 s	Y	Y	0
J157	(Cancel frequency)	OFF 0.0 to 120.0 Hz	Y		0.0
J158	(Cancel deviation level 1)	OFF: Disable 0.01 to 9990.00 *10	Y	Y	OFF
J159	(Cancel delay timer)	0 to 3600s	Y	Y	0
J160	(Cancel deviation level 2)	OFF: Disable 0.01 to 9990.00 *10	Y	Y	OFF

*10 The upper and lower level values are restricted by the maximum and minimum scales.

Code	Name	Data setting range	Change when running	Data copying	Default setting
J163	Flow Sensor (Input selection)	0: Inherit Follow analog input selected by E61, E62, and E63. 1: PV1 20: m ³ /s 21: m ³ /min 22: m ³ /h 23: L/s 24: L/min 25: L/h * Data 20 or larger is to be used for connection of customizable logic.	N	Y	0
J164	(ON level)	0.00 to 9990.00 *10 OFF * If J163 = 20 or above, no scale can be defined, so the setting range should be from the minimum to maximum.	Y	Y	OFF
J165	(OFF level)	0.00 to 9990.00 *10 OFF * If J163 = 20 or above, no scale can be defined, so the setting range should be from the minimum to maximum.	Y	Y	OFF
J166	(Input filter)	0.00 to 5.00s	Y	Y	0.20
J168	Control of Maximum Starts Per Hour (Input selection)	0: Disable 1: Alarm 2: Warning output	Y	Y	0
J169	(Number of slow flowrate stop detections)	1 to 10	Y	Y	1
J176	Dry Pump Protection (Input selection)	0: Disable 1: Alarm 2: Warning output	Y	Y	0
J177	(Detection current)	OFF: Disable 1% to 150% of the inverter rated current	Y	Y	OFF
J178	(Deviation)	OFF: Disable 0.01 to 9990.00 *10	Y	Y	OFF
J179	(Flow sensor)	0: Disable 1: Enable	Y	Y	0
J180	(Detection timer)	0 to 600s	Y	Y	0
J182	End of Curve Protection (Input selection)	0: Disable 1: Alarm 2: Warning output	Y	Y	0
J183	(Detection current)	0.00: Disable 1% to 150% of the inverter rated current	Y	Y	OFF
J184	(Deviation)	0.00: Disable 0.01 to 9990.00 *10	Y	Y	OFF
J185	(Flow sensor)	0: Disable 1: Enable	Y	Y	0
J186	(Detection timer)	0 to 600s	Y	Y	0
J188	Filter Clogging Prevention/ Anti Jam Function (Input selection)	0: Disable 1: Enable (Anti jam protection, inverter stop with rLo trip) 2: Enable (Filter clogging trouble, inverter stop with FoL trip) 3: Enable (While warning (filter clogging trouble) is output, operation is continued.)	Y	Y	0
J189	Filter Clogging Prevention Function (Reverse operation cycle time)	OFF: Disable 1 to 10000 h	Y	Y	720
J190	(Load resistance current)	OFF: Disable 1% to 150% of the inverter rated current	Y	Y	OFF
J191	(Load resistance PV signal)	-999.00 to 0.00 to 9990.00 *10 OFF	Y	Y	OFF
J192	(Load resistance detection timer)	0 to 600 s	Y	Y	0
J193	Filter Clogging Prevention/ Anti Jam Function (Reverse rotation running frequency)	0.0 to 120.0 Hz	Y	Y	5.0
J194	(Reverse rotation running time)	0 to 600 s	Y	Y	30
J195	(Number of allowable reverse runs)	1 to 10 times	Y	Y	3

*10 The upper and lower level values are restricted by the maximum and minimum scales.

J2 codes: PID Control 2

Code	Name	Data setting range	Change when running	Data copying	Default setting
J201	PID Control 2 (Mode selection)	0: Disable 1: Enable (Process control, normal operation) 2: Enable (Process control, inverse operation)	N	Y	0
J202	(Command selection)	0: Keypad (⏏/⏏ key) 1: PID command 1 (Analog input: Terminals [12], [C1] and [V2]) 2: PID command 2 (Analog input: Terminals [12], [C1] and [V2]) 3: UP/DOWN 4: Command via communications link (Use function code S13) 101: Command under PID control 1 (J102)	N	Y	0
J203	(Feedback selection)	1: PID control 1 feedback value 2: PID control 2 feedback value 13: Maximum (PID control 1 feedback value, PID control 2 feedback value)	N	Y	2
J205	(Display unit)	0: Based on the unit/scale of the PID control 2 feedback amount. 1: none 2: % 4: r/min 7: kW <u>Flowrate</u> 20: m ³ /s 21: m ³ /min 22: m ³ /h 23: L/s 24: L/min 25: L/h <u>Pressure</u> 40: Pa 41: kPa 42: MPa 43: mbar 44: bar 45: mmHg 46: psi (Pound per square inch) 47: mWG 48: inWG <u>Temperature</u> 60: K 61: °C 62: °F <u>Density</u> 80: ppm	N	Y	0
J206	(Maximum scale)	-999.00 to 0.00 to 9990.00	N	Y	100
J207	(Minimum scale)	-999.00 to 0.00 to 9990.00	N	Y	0.00
J208	(Tuning)	0: Disable 1: For short-time response 2: For long-time response	Y	Y	0
J209	(Tuning manipulated value)	10 to 100% (Maximum frequency = 100%)	Y	Y	10%
J210	P (Gain)	0.000 to 30.000 times	Y	Y	0.100
J211	I (Integral time)	0.0 to 3600.0 s	Y	Y	0.0
J212	D (Differential time)	0.00 to 600.00 s	Y	Y	0.00
J213	(Feedback filter)	0.0 to 900.0 s	Y	Y	0.5
J214	(Anti-reset wind-up)	OFF: Disable 0.01 to 9990.00 *10	Y	Y	OFF
J218	(Upper limit of PID process output)	0.0 to 120.0 Hz; Inherit (Depends on setting of F15)	Y	Y	Inherit
J219	(Lower limit of PID process output)	0.0 to 120.0 Hz; Inherit (Depends on setting of F16)	Y	Y	Inherit

*10 The upper and lower level values are restricted by the maximum and minimum scales.

Code	Name	Data setting range	Change when running	Data copying	Default setting
J221	PID Control 2 (Alarm output selection)	0: Absolute-value alarm 1: Absolute-value alarm (with Hold) 2: Absolute-value alarm (with Latch) 3: Absolute-value alarm (with Hold and Latch) 4: Deviation alarm 5: Deviation alarm (with Hold) 6: Deviation alarm (with Latch) 7: Deviation alarm (with Hold and Latch) 50: Absolute value alarm (Cancel PID control)	Y	Y	0
J222	(Upper level alarm (AH))	-999 to 0.00 to 9990.00 *10 OFF	Y	Y	OFF
J223	(Upper level alarm detection hysteresis width)	0.00 to 9990.00 *10	Y	Y	0.00
J224	(Lower level alarm (AL))	-999 to 0.00 to 9990.00 *10 OFF	Y	Y	OFF
J225	(Upper level alarm detection hysteresis width)	0.00 to 9990.00 *10	Y	Y	0.00
J227	(Feedback failure detection (Mode selection))	0: Disable (Turns ON output signals (PV2-ERR) and continues operation.) 1: Enable (Free run stop (PV2 trip)) 2: Enable (Deceleration and stop (PV2 trip)) 3: Enable (Continuation of operation at the maximum frequency (upper limit frequency)) 4: Enable (Continuation of operation at the minimum frequency (lower limit frequency)) 5: Enable (Continuation of operation at the frequency used when failure is detected.)	Y	Y	0
J228	(Feedback failure continuation duration)	0 to 3600 s; Inherit 999: After detection of the failure, continue to run as specified by J227. After stop (output shutoff), cause a PV2 trip.	Y	Y	Inherit
J229	(Feedback failure upper-limit)	-999.00 to 0.00 to 9990.00 *10 Auto: 105% equivalent	Y	Y	Auto
J230	(Feedback failure lower-limit)	-999.00 to 0.00 to 9990.00 *10 Auto: -5% equivalent	Y	Y	Auto
J231	(Feedback failure detection time)	0.0 to 300.0 s	Y	Y	0.1
J247	Boost Function (Cancel PV level)	-999.00 to 0.00 to 9990.00 *10 OFF: Disable	Y	Y	OFF
J249	Slow Flowrate Stop Function (Mode selection)	0: Disable (display of OFF) 1: Manual operation (stop judgment: MV) 2: Manual operation (stop judgment: PV)	N	Y	0
J250	(Operation level)	J149 = MV: 0.00 to 120.00 Hz, Auto J149 = PV: 0.00 to 9990.00, Auto *10	Y	Y	Auto
J251	(Elapsed time)	0 to 60s	Y	Y	0
J256	(Initiation inhibition time)	0 to 3600s	Y	Y	0
J257	(Cancel frequency)	0.0 to 120.0 Hz OFF	Y	Y	0.0
J258	(Cancel deviation level 1)	OFF: Disable 0.01 to 9990.00 *10	Y	Y	OFF
J259	(Cancel delay timer)	0 to 3600 s	Y	Y	0
J260	(Cancel deviation level 2)	OFF: Disable 0.01 to 9990.00 *10	Y	Y	OFF
J276	Dry Pump Protection (Input selection)	0: Disable 1: Alarm 2: Warning output	Y	Y	0
J277	(Detection current)	OFF: Disable 1% to 150% of the inverter rated current	Y	Y1	OFF
J278	(Deviation)	OFF: Disable 0.01 to 9990.00 *10	Y	Y	OFF
J279	(Flow sensor)	0: Disable 1: Enable	Y	Y	0
J280	(Detection timer)	0 to 600s	Y	Y	0

*10 The upper and lower level values are restricted by the maximum and minimum scales.

J4 codes: Pump APP Functions

Code	Name	Data setting range	Change when running	Data copying	Default setting
J401	Pump Control Mode Selection	0: Disable 1: Enable (Inverter drive motor fixed system) 2: Enable (Inverter drive motor floating system) 3: Enable (Inverter drive motor floating + commercial power-driven motor system) 52: Enable (Communications-linked inverter drive motor floating system) 54: Enable (Communications-linked all motors simultaneous PID control system)	N	Y	0
J402	Communication Master/Slave Selection	0: Communication master inverter 1: Communication slave inverter	N	Y	1
J403	Number of Slaves	1 or 2 units * Set for a master only.	N	Y	1
J404	Master Input Permeation Selection	0000H to 01FFH (hexadecimal) Bit 0: FWD Bit 1: REV Bit 2: X1 Bit 3: X2 Bit 4: X3 Bit 5: X4 Bit 6: X5 Bit 7: X6 Bit 8: X7 * The inverter sends the master terminal input info to the slave. * The slave stores the received data to S06 after masking.	N	Y	0
J411	Motor 1 Mode Selection	0: Disable (off at all times) 1: Enable 2: Forced drive ON (forced commercial power drive)	Y	Y	0
J412	Motor 2 Mode Selection				
J413	Motor 3 Mode Selection				
J414	Motor 4 Mode Selection				
J415	Motor 5 Mode Selection				
J416	Motor 6 Mode Selection				
J417	Motor 7 Mode Selection				
J418	Motor 8 Mode Selection				
J425	Motor Switching Procedure	0: Fixing procedure 1: Equal operating time (Cumulative run time of each motor is equalized.) 2: Fixing procedure (Switching the motor at slow flowrate stop) 3: Equal operating time (Switching the motor at slow flowrate stop.)	N	Y	0
J430	Stop of Commercial Power-driven Motors	0: Stop commercial power-driven motors 1: Stop commercial power-driven motors only when an inverter alarm occurs 2: Continue to run	Y	Y	0
J435	Motor Regular Switching Mode Selection	1: Inverter-driven pumps are subject to switching. 2: Commercial power-driven pumps are subject to switching. 3: All pumps (inverter-driven pumps/commercial power-driven pumps) are subject to switching.	Y	Y	1
J436	Motor Regular Switching Time	OFF: 0.1 to 720.0 h: Test OFF: Disable 0.1 to 720.0 h: Enable: (Switching time) Test: Enable (Switching time fixed to three minutes)	Y	Y	OFF
J437	Motor Regular Switching Signal Output Time	0.00 to 600.00 s Signal output time	Y	Y	0.10
J450	Motor Increase Judgment (Judgment frequency)	0 to 120 Hz, Inherit Inherit: Depends on J118	Y	Y	Inherit
J451	(Duration time)	0.00 to 3600.00 s	Y	Y	0.00
J452	Motor Decrease Judgment (Judgment frequency)	0 to 120 Hz, Inherit Inherit: Depends on J119	Y	Y	Inherit
J453	(Duration time)	0.00 to 3600.00 s	Y	Y	0.00
J454	Contactorm Restart Time when Switching the Motor	0.01 to 2.00 s	Y	Y	0.10
J455	Motor Increase Switching Time (Deceleration time)	Inherit: Depends on F08 0.01 to 3600.00 s	Y	Y	Inherit
J456	Motor Increase Switching Level	0 to 100%	Y	Y	0
J457	Motor Increase PID Control Start Frequency	0 to 120 Hz, Inherit Depends on J452	Y	Y	Inherit
J458	Motor Decrease Switching Time (Acceleration time)	Inherit: Depends on F07 0.01 to 3600.00 s	Y	Y	Inherit

Code	Name	Data setting range	Change when running	Data copying	Default setting
J459	Motor Decrease Switching Level	0 to 100%, Inherit Inherit: Depends on J456	Y	Y	Inherit
J460	Motor Decrease PID Control Start Frequency	0 to 120 Hz, Inherit Inherit: Depends on J450	Y	Y	Inherit
J461	Motor Increase/Decrease Switching Judgment Non-responsive Area Width	OFF, 0.1 to 50.0% OFF: Disable 0.1 to 50.0%	Y	Y	OFF
J462	Failure Inverter Judgment Time	OFF, 0.5 to 600.0 s	Y	Y	5.0
J465	Auxiliary Motor (Frequency operation level)	0.1 to 120.0 Hz OFF: Disable	Y	Y	50.0
J466	(Hysteresis width)	0.0 to 120.0 Hz	Y	Y	1.0
J467	(PV operation level)	0.01 to 9990.00 *10 OFF: Disable	Y	Y	OFF
J468	(Connection timer)	0.00 to 2.00 s	Y	Y	0.00
J469	(Interrupting timer)	0.00 to 2.00 s	Y	Y	0.00
J480	Motor Cumulative Run Time (Motor 0)	0 to 65535 For adjustment at the replacement time	Y	N	0
J481	(Motor 1)				
J482	(Motor 2)				
J483	(Motor 3)				
J484	(Motor 4)				
J485	(Motor 5)				
J486	(Motor 6)				
J487	(Motor 7)				
J488	(Motor 8)				
J490	Y Terminal ON Maximum Cumulation Count (Y1 Y2)	0.000 to 9999 (The display of "1.000" indicates 1000 times.)	Y	N	0.000
J491	(Y3 Y4)				
J492	Relay ON Maximum Cumulation Count (Y5A 30AB)				
J493	(Y6RY to Y12RY)				

J5 codes: External PID Function 1

Code	Name	Data setting range	Change when running	Data copying	Default setting
J501	External PID Control 1 (Mode selection)	0 Disable 1: Enable process control (Normal operation) 2: Enable process control (Inverse operation) 11: Enable process control, interlocking with inverter running (Normal operation) 12: Enable process control, interlocking with inverter running (Inverse operation) 21: Enable process control by external digital signal (Normal operation) 22: Enable process control by external digital signal (Inverse operation) 31: Enable process control by external digital signal, interlocking with inverter running (Normal operation) 32: Enable process control by external digital signal, interlocking with inverter running (Inverse operation)	N	Y	0
J502	(Remote command selection)	0: Keypad (⏏ key) 3: UP/DOWN 4: Command via communications link (Use function code S13) 51: External PID command 1 (Analog input: Terminals [12], [C1] and [V2])	N	Y	0
J503	(Feedback selection)	51: External PID feedback value 1 60: Addition (External PID feedback value 1 + External PID feedback value 2) 61: Difference External PID feedback value 1 - External PID feedback value 2 62: Average (External PID feedback value 1, External PID feedback value 2) 63: Maximum (External PID feedback value 1, External PID feedback value 2) 64: Minimum (External PID feedback value 1, External PID feedback value 2)	N	Y	51

*10 The upper and lower level values are restricted by the maximum and minimum scales.

Code	Name	Data setting range	Change when running	Data copying	Default setting
J504	External PID Control 1 (Deviation selection)	0: (J5-02) - (J5-03) 51: Maximum (Maximum deviation between external PID control 1 and 2) 52: Minimum (Minimum deviation between external PID control 1 and 2)	N	Y	0
J505	(Display unit)	0: Based on the unit/scale of the PID control 1 feedback amount 1: none 2: % 4: r/min 7: kW <u>Flowrate</u> 20: m ³ /s 21: m ³ /min 22: m ³ /h 23: L/s 24: L/min 25: L/h <u>Pressure</u> 40: Pa 41: kPa 42: MPa 43: mbar 44: bar 45: mmHg 46: psi (Pound per square inch) 47: mWG 48: inWG <u>Temperature</u> 60: K 61: °C 62: °F <u>Density</u> 80: ppm	N	Y	0
J506	(Maximum scale)	-999.00 to 0.00 to 9990.00	N	Y	100.00
J507	(Minimum scale)	-999.00 to 0.00 to 9990.00	N	Y	0.00
J510	P (Gain)	0.000 to 30.000 times ON/OFF: ON/OFF control	Y	Y	0.100
J511	I (Integral time)	0.0 to 3600.0 s	Y	Y	0.0
J512	D (Differential time)	0.00 to 600.00 s	Y	Y	0.00
J513	(Feedback filter)	0.0 to 900.0 s	Y	Y	0.5
J514	(Anti-reset wind-up)	OFF: Disable 0.00 to 9990.00 *10	Y	Y	OFF
J515	(ON/OFF control hysteresis width)	0.00 to 9990.00 *10	Y	Y	0.00
J516	(Proportional operation output convergent value)	0 to 150%	Y	Y	0
J517	(Proportional cycle)	1 to 150 s	Y	Y	30
J518	(Upper limit of PID process output)	-10 to +110%	Y	Y	100
J519	(Lower limit of PID process output)	-10 to +110%	Y	Y	0
J520	(Upper and lower limits)	0: Limit PID output with J518, J519 1: 110%, -10% of PID output with J518 exceeded or less than J519	Y	Y	0
J521	(Alarm output selection)	0: Absolute-value alarm (PV) 1: Absolute-value alarm (PV) (with Hold) 2: Absolute-value alarm (PV) (with Latch) 3: Absolute-value alarm (PV) (with Hold and Latch) 4: Deviation alarm (PV) 5: Deviation alarm (PV) (with Hold) 6: Deviation alarm (PV) (with Latch) 7: Deviation alarm (PV) (with Hold and Latch) 8: Absolute-value alarm (SV) 9: Absolute-value alarm (SV) (with Hold) 10: Absolute-value alarm (SV) (with Latch) 11: Absolute-value alarm (SV) (with Hold and Latch) 12: Absolute-value alarm (MV) 13: Absolute-value alarm (MV) (with Hold) 14: Absolute-value alarm (MV) (with Latch) 15: Absolute-value alarm (MV) (with Hold and Latch)	Y	Y	0

*10 The upper and lower level values are restricted by the maximum and minimum scales.

Code	Name	Data setting range	Change when running	Data copying	Default setting
J522	External PID Control 1 (Upper level alarm (AH))	-999.00 to 0.00 to 9990.00 *10 OFF	Y	Y	OFF
J524	(Lower level alarm (AL))	-999.00 to 0.00 to 9990.00 *10 OFF	Y	Y	OFF
J527	(Feedback error detection mode)	0: Disable (Turns ON output signals (EPV1-ERR) and continues operation.) 1: Enable (Free run stop (PVA trip)) 2: Enable (Deceleration and stop (PVA trip))	Y	Y	0
J529	(Feedback error upper-limit)	-999.00 to 0.00 to 9990.00 *10 Auto: 105% equivalent	Y	Y	Auto
J530	(Feedback error lower-limit)	-999.00 to 0.00 to 9990.00 *10 Auto: -5% equivalent	Y	Y	Auto
J531	(Feedback error detection time)	0.0 to 300.0 s	Y	Y	0.1
J540	(Manual command)	0: Keypad (⏏) key 8: Keypad (⏏) key (Balanceless-bumpless) 51: External PID command 1 (Analog input: Terminals [12], [C1] and [V2])	N	Y	0
J550	External PID Multistep Command (Mode selection)	Bit 0: Enable multistep command under external PID control 1 Bit 1: Enable multistep command under external PID control 2 Bit 2: Enable multistep command under external PID control 3	N	Y	0
J551	(Multistep command 1)	-999.00 to 0.00 to 9990.00	Y	Y	0.00
J552	(Multistep command 2)	-999.00 to 0.00 to 9990.00	Y	Y	0.00
J553	(Multistep command 3)	-999.00 to 0.00 to 9990.00	Y	Y	0.00

J6 codes: External PID Function 2/3

Code	Name	Data setting range	Change when running	Data copying	Default setting
J601	External PID Control 2 (Mode selection)	0: Disable 1: Enable process control (Normal operation) 2: Enable process control (Inverse operation) 11: Enable process control, interlocking with inverter running (Normal operation) 12: Enable process control, interlocking with inverter running (Inverse operation) 21: Enable process control by external digital signal (Normal operation) 22: Enable process control by external digital signal (Inverse operation) 31: Enable process control by external digital signal, interlocking with inverter running (Normal operation) 32: Enable process control by external digital signal, interlocking with inverter running (Inverse operation)	N	Y	0
J602	(Remote command selection)	0: Keypad (⏏) key 3: UP/DOWN 4: Command via communications link 51: External PID command 1 (Analog input terminals [12], [C1] and [V2]) 52: External PID command 2 (Analog input terminals [12], [C1] and [V2]) 111: Apply external PID control 1 commands	N	Y	0
J603	(Feedback selection)	51: External PID feedback value 1 52: External PID feedback value 2	N	Y	52

*10 The upper and lower level values are restricted by the maximum and minimum scales.

Code	Name	Data setting range	Change when running	Data copying	Default setting
J605	External PID Control 2 (Display unit)	0: Based on the unit/scale of the PID control 1 feedback amount 1: none 2: % 4: r/min 7: kW <u>Flowrate</u> 20: m ³ /s 21: m ³ /min 22: m ³ /h 23: L/s 24: L/min 25: L/h <u>Pressure</u> 40: Pa 41: kPa 42: MPa 43: mbar 44: bar 45: mmHg 46: psi (Pound per square inch) 47: mWG 48: inWG <u>Temperature</u> 60: K 61: °C 62: °F <u>Density</u> 80: ppm	N	Y	0
J606	(Maximum scale)	-999.00 to 0.00 to 9990.00	N	Y	100.00
J607	(Minimum scale)	-999.00 to 0.00 to 9990.00	N	Y	0.00
J610	P (Gain)	0.000 to 30.000 times ON/OFF control	Y	Y	0.100
J611	I (Integral time)	0.0 to 3600.0 s	Y	Y	0.0
J612	D (Differential time)	0.00 to 600.00 s	Y	Y	0.00
J613	(Feedback filter)	0.0 to 900.0 s	Y	Y	0.5
J614	(Anti-reset wind-up)	OFF: Disable 0.01 to 9990.00 *10	Y	Y	OFF
J615	(ON/OFF control hysteresis width)	0.00 to 9990.00 *10	Y	Y	0.00
J616	(Proportional operation output convergent value)	0 to 150%	Y	Y	0
J617	(Proportion cycle)	1 to 150 s	Y	Y	30
J618	(Upper limit of PID process output)	-10 to 110%	Y	Y	100
J619	(Lower limit of PID process output)	-10 to 110%	Y	Y	0
J620	(Upper and lower limits)	0: Limit PID output with J618, J619 1: 110%, -10% of PID output with J618 exceeded or less than J619	Y	Y	0
J621	(Alarm output selection)	0: Absolute-value alarm (PV) 1: Absolute-value alarm (PV) (with Hold) 2: Absolute-value alarm (PV) (with Latch) 3: Absolute-value alarm (PV) (with Hold and Latch) 4: Deviation alarm (PV) 5: Deviation alarm (PV) (with Hold) 6: Deviation alarm (PV) (with Latch) 7: Deviation alarm (PV) (with Hold and Latch) 8: Absolute-value alarm (SV) 9: Absolute-value alarm (SV) (with Hold) 10: Absolute-value alarm (SV) (with Latch) 11: Absolute-value alarm (SV) (with Hold and Latch) 12: Absolute-value alarm (MV) 13: Absolute-value alarm (MV) (with Hold) 14: Absolute-value alarm (MV) (with Latch) 15: Absolute-value alarm (MV) (with Hold and Latch)	Y	Y	0
J622	(Upper level alarm (AH))	-999.00 to 0.00 to 9990.00 *10 OFF	Y	Y	OFF
J624	(Lower level alarm (AL))	-999.00 to 0.00 to 9990.00 *10 OFF	Y	Y	OFF
J627	(Feedback error detection mode)	0: Disable (Turns ON output signals (EPV2-ERR) and continues operation.) 1: Enable (Free run stop (PVb trip)) 2: Enable (Deceleration and stop (PVb trip))	Y	Y	0

*10 The upper and lower level values are restricted by the maximum and minimum scales.

Code	Name	Data setting range	Change when running	Data copying	Default setting
J629	External PID Control 2 (Feedback error upper-limit)	-999.00 to 0.00 to 9990.00 *10 Auto: 105% equivalent	Y	Y	Auto
J630	(Feedback error lower-limit)	-999.00 to 0.00 to 9990.00 *10 Auto: -5% equivalent	Y	Y	Auto
J631	(Feedback error detection time)	0.0 to 300.0 s	Y	Y	0.1
J640	(Manual command)	0: Keypad (⏏) key 8: Keypad (⏏) key (Balanceless-bumpless) 51: External PID manual command 1 (Analog input: Terminals [12], [C1] and [V2]) 51: External PID manual command 2 (Analog input: Terminals [12], [C1] and [V2]) 111: Apply external PID control 1 manual command	N	Y	0
J651	External PID Control 3 (Mode selection)	0: Disable 1: Enable process control (Normal operation) 2: Enable process control (Inverse operation) 11: Enable process control, interlocking with inverter running (Normal operation) 12: Enable process control, interlocking with inverter running (Inverse operation) 21: Enable process control by external digital signal (Normal operation) 22: Enable process control by external digital signal (Inverse operation) 31: Enable process control by external digital signal, interlocking with inverter running (Normal operation) 32: Enable process control by external digital signal, interlocking with inverter running (Inverse operation)	N	Y	0
J652	External PID Control 3 (Remote command selection)	0: Keypad (⏏) key 3: UP/DOWN 4: Command via communications link (Use function code S32) 51: External PID process command 1 (Analog input: Terminals [12], [C1] and [V2]) 52: External PID process command 2 (Analog input: Terminals [12], [C1] and [V2]) 53: External PID process command 3 (Analog input: Terminals [12], [C1] and [V2]) 111: Apply external PID control 1 commands 112: Apply external PID control 2 commands	N	Y	0
J653	(Feedback selection)	51: External PID feedback value 1 52: External PID feedback value 2 53: External PID feedback value 3	N	Y	53
J655	(Display unit)	See J605.	N	Y	0
J656	(Maximum scale)	-999.00 to 0.00 to 9990.00	N	Y	100
J657	(Minimum scale)	-999.00 to 0.00 to 9990.00	N	Y	0.00
J660	P (Gain)	0.000 to 30.000 times ON/OFF: ON/OFF control	Y	Y	0.100
J661	I (Integral time)	0.0 to 3600.0 s	Y	Y	0.0
J662	D (Differential time)	0.00 to 600.00 s	Y	Y	0.00
J663	(Feedback filter)	0.0 to 900.0 s	Y	Y	0.5
J664	(Anti-reset wind-up)	0.00 to 9990.00 *10 OFF: Disable	Y	Y	OFF
J665	(ON/OFF control hysteresis width)	0.00 to 9990.00 *10	Y	Y	0.00
J666	(Proportional operation output convergent value)	0 to 150%	Y	Y	0
J667	(Proportion cycle)	1 to 150 s	Y	Y	30
J668	(Upper limit of PID process output)	-10 to +110%	Y	Y	100
J669	(Lower limit of PID process output)	-10 to +110%	Y	Y	0
J670	(Upper and lower limits)	0: Limit PID output with J618, J619 1: 110%, -10% of PID output with J618 exceeded or less than J619	Y	Y	0

*10 The upper and lower level values are restricted by the maximum and minimum scales.

Code	Name	Data setting range	Change when running	Data copying	Default setting
J671	(Alarm output selection)	0: Absolute-value alarm (PV) 1: Absolute-value alarm (PV) (with Hold) 2: Absolute-value alarm (PV) (with Latch) 3: Absolute-value alarm (PV) (with Hold and Latch) 4: Deviation alarm 5: Deviation alarm (PV) (with Hold) 6: Deviation alarm (PV) (with Latch) 7: Deviation alarm (PV) (with Hold and Latch) 8: Absolute-value alarm (SV) 9: Absolute-value alarm (SV) (with Hold) 10: Absolute-value alarm (SV) (with Latch) 11: Absolute-value alarm (SV) (with Hold and Latch) 12: Absolute-value alarm (MV) 13: Absolute-value alarm (MV) (with Hold) 14: Absolute-value alarm (MV) (with Latch) 15: Absolute-value alarm (MV) (with Hold and Latch)	Y	Y	0
J672	(Upper level alarm (AH))	-999.00 to 0.00 to 9990.00 *10 OFF	Y	Y	OFF
J674	(Lower level alarm (AL))	-999.00 to 0.00 to 9990.00 *10 OFF	Y	Y	OFF
J677	(Feedback error detection mode)	0: Disable (Turns ON output signals (EPV3-ERR) and continues operation.) 1: Enable (Free run stop (PVC trip)) 2: Enable (Deceleration and stop (PVC trip))	Y	Y	0
J679	(Feedback error upper-limit)	-999.00 to 0.00 to 9990.00 *10 Auto: 105% equivalent	Y	Y	Auto
J680	(Feedback error lower-limit)	-999.00 to 0.00 to 9990.00 *10 Auto: -5% equivalent	Y	Y	Auto
J681	(Feedback error detection time)	0.0 to 300.0 s	Y	Y	0.1
J690	(Manual commands)	0: Keypad (↖↗ key) 8: Keypad (↖↗ key) (Balanceless-bumpless) 51: External PID manual command 1 (Analog input: Terminals [12], [C1] and [V2]) 52: External PID manual command 2 (Analog input: Terminals [12], [C1] and [V2]) 53: External PID manual command 3 (Analog input: Terminals [12], [C1] and [V2]) 111: Apply external PID control 1 manual commands 112: Apply external PID control 2 manual commands	N	Y	0

*10 The upper and lower level values are restricted by the maximum and minimum scales.

d codes: Application Functions 2

Code	Name	Data setting range	Change when running	Data copying	Default setting
d51	Reserved *9	0 to 500	N	Y	-
d55	Reserved *9	0000H to 00FFH	N	Y	0
d69	Reserved *9	30.0 to 100.0 Hz	Y	Y	30.0
d98	Reserved *9	0000H to FFFFH	Y	Y	0
d99	Reserved *9	0 to 3	Y	Y	0

*9 These function codes are reserved for particular manufacturers. Unless otherwise specified, do not access these function codes.

U codes: Customizable Logic Function

Code	Name	Data setting range	Change when running	Data copying	Default setting
U00	Customizable Logic (Mode selection)	0: Disable 1: Enable (Customizable logic operation) Changing this code data from "1" to "0" causes an ECL alarm.	Y	Y	0
U01	Customizable Logic: Step 1 (Control function)	0: No function assigned 10: Through output + General-purpose timer 20: ANDing + General-purpose timer 30: ORing + General-purpose timer 40: XORing + General-purpose timer 50: Set priority flip-flop + General-purpose timer 60: Reset priority flip-flop + General-purpose timer 70: Rising edge detector + General-purpose timer 80: Falling edge detector + General-purpose timer 90: Rising & falling edges detector + General-purpose timer 100: Hold + General-purpose timer 110: Increment counter 120: Decrement counter 130: Timer with reset input 2001-3002: Analog input 4001-5114: Analog + digital	N	Y	0
U02 U03	(Input 1)	0 (1000): Inverter running (<i>RUN</i>) 1 (1001): Frequency (speed) arrival signal (<i>FAR</i>) 2 (1002): Frequency (speed) detected (<i>FDT</i>) 3 (1003): Undervoltage detected (Inverter stopped) (<i>LV</i>) 5 (1005): Inverter output limiting (<i>IOL</i>) 6 (1006): Auto-restarting after momentary power failure (<i>IPF</i>) 7 (1007): Motor overload early warning (<i>OL</i>) 10 (1010): Inverter ready to run (<i>RDY</i>) 11: Switch motor drive source between commercial power and inverter output (For MC on commercial line) (<i>SW88</i>) 12: Switch motor drive source between commercial power and inverter output (For secondary side) (<i>SW52-2</i>) 13: Switch motor drive source between commercial power and inverter output (For primary side) (<i>SW52-1</i>) 15 (1015): Select <i>AX</i> terminal function (For MC on primary side) (<i>AX</i>) 16 (1016): Shifted to pattern operation stage (<i>TU</i>) 17 (1017): Pattern operation cycle completed (<i>TO</i>) 18 (1018): Pattern operation stage number (<i>STG1</i>) 19 (1019): Pattern operation stage number (<i>STG2</i>) 20 (1020): Pattern operation stage number (<i>STG4</i>) 22 (1022): Inverter output limiting with delay (<i>IOL2</i>) 25 (1025): Cooling fan in operation (<i>FAN</i>) 26 (1026): Auto-resetting (<i>TRY</i>) 27 (1027): Universal DO (<i>U-DO</i>) 28 (1028): Heat sink overheat early warning (<i>OH</i>) 30 (1030): Lifetime alarm (<i>LIFE</i>) 33 (1033): Reference loss detected (<i>REF OFF</i>) 35 (1035): Inverter output on (<i>RUN2</i>) 36 (1036): Overload prevention control (<i>OLP</i>) 37 (1037): Current detected (<i>ID</i>) 42 (1042): PID alarm (<i>PID-ALM</i>) 43 (1043): Under PID control (<i>PID-CTL</i>) 44 (1044): Motor stopped due to slow flowrate under PID control (<i>PID-STP</i>) 45 (1045): Low output torque detected (<i>U-TL</i>) 52 (1052): Running forward (<i>FRUN</i>) 53 (1053): Running reverse (<i>RRUN</i>) 54 (1054): In remote operation (<i>RMT</i>) 55 (1055): Run command entered (<i>AX2</i>) 56 (1056): Motor overheat detected by thermistor (<i>THM</i>) 59 (1059): Terminal [C1] wire break (<i>C1OFF</i>) 68 (1068): Motor regular switching early warning (<i>MCHG</i>) 69 (1069): Pump control output limit signal (<i>MLIM</i>)	N	Y	100

Code	Name	Data setting range	Change when running	Data copying	Default setting
	84 (1084):	Maintenance timer	(MNT)		
	87(1087):	Frequency arrival signal	(FARFDT)		
	88(1088):	Auxiliary motor drive signal	(AUX_L)		
	95(1095):	Running in fire mode	(FMRUN)		
	98 (1098):	Light alarm	(L-ALM)		
	99 (1099):	Alarm output (for any alarm)	(ALM)		
	101(1101):	EN terminal detection circuit error	(DECF)		
	102(1102):	EN terminal OFF	(ENOFF)		
	111 (1111):	Customizable logic output signal 1	(CLO1)		
	112 (1112):	Customizable logic output signal 2	(CLO2)		
	113 (1113):	Customizable logic output signal 3	(CLO3)		
	114 (1114):	Customizable logic output signal 4	(CLO4)		
	115 (1115):	Customizable logic output signal 5	(CLO5)		
	116 (1116):	Customizable logic output signal 6	(CLO6)		
	117 (1117):	Customizable logic output signal 7	(CLO7)		
	160 (1160):	Motor 1 being driven by inverter	(M1_I)		
	161 (1161):	Motor 1 being driven by commercial power	(M1_L)		
	162 (1162):	Motor 2 being driven by inverter	(M2_I)		
	163 (1163):	Motor 2 being driven by commercial power	(M2_L)		
	164 (1164):	Motor 3 being driven by inverter	(M3_I)		
	165 (1165):	Motor 3 being driven by commercial power	(M3_L)		
	166 (1166):	Motor 4 being driven by inverter	(M4_I)		
	167 (1167):	Motor 4 being driven by commercial power	(M4_L)		
	169 (1169):	Motor 5 being driven by commercial power	(M5_L)		
	171 (1171):	Motor 6 being driven by commercial power	(M6_L)		
	173 (1173):	Motor 7 being driven by commercial power	(M7_L)		
	175 (1175):	Motor 8 being driven by commercial power	(M8_L)		
	180 (1180):	In mutual operation	(M-RUN)		
	181 (1181):	Alarm in mutual operation	(M-ALM)		
	190 (1190):	In timer operation	(TMD)		
	191 (1191):	Timer 1 enabled	(TMD1)		
	192 (1192):	Timer 2 enabled	(TMD2)		
	193 (1193):	Timer 3 enabled	(TMD3)		
	194 (1194):	Timer 4 enabled	(TMD4)		
	200 (1200):	Under PID2 control	(PID2)		
	201 (1201):	PID1 alarm	(PV1-ALM)		
	202 (1202):	PID1 feedback error	(PV1-OFF)		
	203 (1203):	PID2 alarm	(PV2-ALM)		
	204 (1204):	PID2 feedback error	(PV2-OFF)		
	211 (1211):	Under external PID1 control	(EPID1-CTL)		
	212 (1212):	External PID1 output	(EPID1-OUT)		
	213 (1213):	External PID1 output	(EPID1-RUN)		
	214 (1214):	External PID1 alarm	(EPV1-ALM)		
	215 (1215):	External PID1 feedback error	(EPV1-OFF)		
	221 (1221):	Under external PID2 control	(EPID2-CTL)		
	222 (1222):	External PID2 output	(EPID2-OUT)		
	223 (1223):	External PID2 output	(EPID2-RUN)		
	224 (1224):	External PID2 alarm	(EPV2-ALM)		
	225 (1225):	External PID2 feedback error	(EPV2-OFF)		
	231 (1231):	Under external PID3 control	(EPID3-CTL)		
	232 (1232):	External PID3 output	(EPID3-OUT)		
	233 (1233):	External PID3 output	(EPID3-RUN)		
	234 (1234):	External PID3 alarm	(EPV3-ALM)		
	235 (1235):	External PID3 feedback error	(EPV3-OFF)		
	2001 (3001):	Output of step 1	(SO01)		
	2002 (3002):	Output of step 2	(SO02)		
	2003 (3003):	Output of step 3	(SO03)		
	2004 (3004):	Output of step 4	(SO04)		
	2005 (3005):	Output of step 5	(SO05)		
	2006 (3006):	Output of step 6	(SO06)		
	2007 (3007):	Output of step 7	(SO07)		
	2008 (3008):	Output of step 8	(SO08)		
	2009 (3009):	Output of step 9	(SO09)		
	2010 (3010):	Output of step 10	(SO10)		
	2011 (3011):	Output of step 11	(SO11)		
	2012 (3012):	Output of step 12	(SO12)		
	2013 (3013):	Output of step 13	(SO13)		
	2014 (3014):	Output of step 14	(SO14)		

Code	Name	Data setting range	Change when running	Data copying	Default setting
		4001 (5001): Terminal [X1] input signal (X1) 4002 (5002): Terminal [X2] input signal (X2) 4003 (5003): Terminal [X3] input signal (X3) 4004 (5004): Terminal [X4] input signal (X4) 4005 (5005): Terminal [X5] input signal (X5) 4006 (5006): Terminal [X6] input signal (X6) 4007 (5007): Terminal [X7] input signal (X7) 4010 (5010): Terminal [FWD] input signal (FWD) 4011 (5011): Terminal [REV] input signal (REV) 6000 (7000): Final run command (FL_RUN) 6001 (7001): Final FWD run command (FL_FWD) 6002 (7002): Final REV run command (FL_REV) 6003 (7003): During acceleration (DACC) 6004 (7004): During deceleration (DDEC) 6005 (7005): Under anti-regenerative control (REGA) 6007 (7007): Alarm factor presence (ALM_ACT) Setting the value in parentheses () shown above assigns a negative logic output to a terminal. (True if OFF.) Setting the value of 1000s in parentheses () shown above assigns a negative logic input to a terminal.			
U04	(Function 1)	-9990.00 to 0.00 to 9990.00	N	Y	0.00
U05	(Function 2)		N	Y	0.00
U06	Customizable Logic: Step 2 (Control function)	See U01.	N	Y	0
U07	(Input 1)	See U02.	N	Y	100
U08	(Input 2)	See U02.	N	Y	100
U09	(Function 1)	-9990.00 to 0.00 to 9990.00	N	Y	0.00
U10	(Function 2)	-9990.00 to 0.00 to 9990.00	N	Y	0.00
U11	Customizable Logic: Step 3 (Control function)	See U01.	N	Y	0
U12	(Input 1)	See U02.	N	Y	100
U13	(Input 2)	See U02.	N	Y	100
U14	(Function 1)	-9990.00 to 0.00 to 9990.00	N	Y	0.00
U15	(Function 2)	-9990.00 to 0.00 to 9990.00	N	Y	0.00
U16	Customizable Logic: Step 4 (Control function)	See U01.	N	Y	0
U17	(Input 1)	See U02.	N	Y	100
U18	(Input 2)	See U02.	N	Y	100
U19	(Function 1)	-9990.00 to 0.00 to 9990.00	N	Y	0.00
U20	(Function 2)	-9990.00 to 0.00 to 9990.00	N	Y	0.00
U21	Customizable Logic: Step 5 (Control function)	See U01.	N	Y	0
U22	(Input 1)	See U02.	N	Y	100
U23	(Input 2)	See U02.	N	Y	100
U24	(Function 1)	-9990.00 to 0.00 to 9990.00	N	Y	0.00
U25	(Function 2)	-9990.00 to 0.00 to 9990.00	N	Y	0.00
U26	Customizable Logic: Step 6 (Control function)	See U01.	N	Y	0
U27	(Input 1)	See U02.	N	Y	100
U28	(Input 2)	See U02.	N	Y	100
U29	(Function 1)	-9990.00 to 0.00 to 9990.00	N	Y	0.00
U30	(Function 2)	-9990.00 to 0.00 to 9990.00	N	Y	0.00
U31	Customizable Logic: Step 7 (Control function)	See U01.	N	Y	0
U32	(Input 1)	See U02.	N	Y	100
U33	(Input 2)	See U02.	N	Y	100
U34	(Function 1)	-9990.00 to 0.00 to 9990.00	N	Y	0.00
U35	(Function 2)	-9990.00 to 0.00 to 9990.00	N	Y	0.00
U36	Customizable Logic: Step 8 (Control function)	See U01.	N	Y	0
U37	(Input 1)	See U02.	N	Y	100
U38	(Input 2)	See U02.	N	Y	100
U39	(Function 1)	-9990.00 to 0.00 to 9990.00	N	Y	0.00
U40	(Function 2)	-9990.00 to 0.00 to 9990.00	N	Y	0.00
U41	Customizable Logic: Step 9 (Control function)	See U01.	N	Y	0
U42	(Input 1)	See U02.	N	Y	100
U43	(Input 2)	See U02.	N	Y	100
U44	(Function 1)	-9990.00 to 0.00 to 9990.00	N	Y	0.00
U45	(Function 2)	-9990.00 to 0.00 to 9990.00	N	Y	0.00

Code	Name	Data setting range	Change when running	Data copying	Default setting
U46	Customizable Logic: Step 10 (Control function)	See U01.	N	Y	0
U47	(Input 1)	See U02.	N	Y	100
U48	(Input 2)	See U02.	N	Y	100
U49	(Function 1)	-9990.00 to 0.00 to 9990.00	N	Y	0.00
U50	(Function 2)	-9990.00 to 0.00 to 9990.00	N	Y	0.00
U51	Customizable Logic: Step 11 (Control function)	See U01.	N	Y	0
U52	(Input 1)	See U02.	N	Y	100
U53	(Input 2)	See U02.	N	Y	100
U54	(Function 1)	-9990.00 to 0.00 to 9990.00	N	Y	0.00
U55	(Function 2)	-9990.00 to 0.00 to 9990.00	N	Y	0.00
U56	Customizable Logic: Step 12 (Control function)	See U01.	N	Y	0
U57	(Input 1)	See U02.	N	Y	100
U58	(Input 2)	See U02.	N	Y	100
U59	(Function 1)	-9990.00 to 0.00 to 9990.00	N	Y	0.00
U60	(Function 2)	-9990.00 to 0.00 to 9990.00	N	Y	0.00
U61	Customizable Logic: Step 13 (Control function)	See U01.	N	Y	0
U62	(Input 1)	See U02.	N	Y	100
U63	(Input 2)	See U02.	N	Y	100
U64	(Function 1)	-9990.00 to 0.00 to 9990.00	N	Y	0.00
U65	(Function 2)	-9990.00 to 0.00 to 9990.00	N	Y	0.00
U66	Customizable Logic: Step 14 (Control function)	See U01.	N	Y	0
U67	(Input 1)	See U02.	N	Y	100
U68	(Input 2)	See U02.	N	Y	100
U69	(Function 1)	-9990.00 to 0.00 to 9990.00	N	Y	0.00
U70	(Function 2)	-9990.00 to 0.00 to 9990.00	N	Y	0.00
U71	Customizable Logic Output Signal 1 (Output selection)	0: Disable 1: Output of step 1 2: Output of step 2 3: Output of step 3 4: Output of step 4 5: Output of step 5 6: Output of step 6 7: Output of step 7 8: Output of step 8 9: Output of step 9 10: Output of step 10 11: Output of step 11 12: Output of step 12 13: Output of step 13 14: Output of step 14	N	Y	0
U72	Customizable Logic Output Signal 2	(SO01)	N	Y	0
U73	Customizable Logic Output Signal 3	(SO02)	N	Y	0
U74	Customizable Logic Output Signal 4	(SO03)	N	Y	0
U75	Customizable Logic Output Signal 5	(SO04)	N	Y	0
U76	Customizable Logic Output Signal 6	(SO05)	N	Y	0
U77	Customizable Logic Output Signal 7	(SO06)	N	Y	0
		(SO07)	N	Y	0
		(SO08)			
		(SO09)			
		(SO10)			
		(SO11)			
		(SO12)			
		(SO13)			
		(SO14)			
U81	Customizable Logic Output Signal 1 (Function selection)	0 (1000): Select multistep frequency (0 to 1 step) (SS1) 1 (1001): Select multistep frequency (0 to 3 steps) (SS2) 2 (1002): Select multistep frequency (0 to 7 steps) (SS4) 3 (1003): Select multistep frequency (0 to 15 steps) (SS8) 4 (1004): Select ACC/DEC time (2 steps) (RT1) 5 (1005): Select ACC/DEC time (4 steps) (RT2) 6 (1006): Enable 3-wire operation (HLD) 7 (1007): Coast to a stop (BX) 8 (1008): Reset alarm (RST) 9 (1009): Enable external alarm trip (THR) (9 = Active OFF, 1009 = Active ON) 11 (1011): Select frequency command 2/1 (Hz2/Hz1) 13: Enable DC braking (DCBRK) 14 (1014): Select torque limiter level 2/1 (TL2/TL1) 15: Switch to commercial power (50 Hz) (SW50) 16: Switch to commercial power (60 Hz) (SW60) 17 (1017): UP (Increase output frequency) (UP) 18 (1018): DOWN (Decrease output frequency) (DOWN) 20 (1020): Cancel PID control (Hz/PID) 21 (1021): Switch normal/inverse operation (IVS) 22 (1022): Interlock (IL)	N	Y	100
U82	Customizable Logic Output Signal 2		N	Y	100
U83	Customizable Logic Output Signal 3		N	Y	100
U84	Customizable Logic Output Signal 4		N	Y	100
U85	Customizable Logic Output Signal 5		N	Y	100
U86	Customizable Logic Output Signal 6		N	Y	100
U87	Customizable Logic Output Signal 7		N	Y	100

Code	Name	Data setting range	Change when running	Data copying	Default setting
		24 (1024): Enable communications link via RS-485 or fieldbus (LE)			
		25 (1025): Universal DI (U-DI)			
		26 (1026): Enable auto search for idling motor speed at starting (STM)			
		30 (1030): Force to stop (STOP)			
		(30 = Active OFF, 1030 = Active ON)			
		33 (1033): Reset PID integral and differential components (PID-RST)			
		34 (1034): Hold PID integral component (PID-HLD)			
		35 (1035): Select local (keypad) operation (LOC)			
		38 (1038): Enable run commands (RE)			
		39: Protect motor from dew condensation (DWP)			
		40: Enable integrated sequence to switch to commercial power (50 Hz) (ISW50)			
		41: Enable integrated sequence to switch to commercial power (60 Hz) (ISW60)			
		50 (1050): Clear running motor regular switching time (MCLR)			
		58 (1058): Reset UP/DOWN frequency (STZ)			
		72 (1072): Count the run time of commercial power-driven motor 1 (CRUN-M1)			
		81 (1081): Clear all customizable logic timers (CLTC)			
		87 (1087): Run command 2/1 (FR2/FR1)			
		88: Run forward 2 (FWD2)			
		89: Run reverse 2 (REV2)			
		98: Run forward (FWD)			
		99: Run reverse (REV)			
		100: No function assigned (NONE)			
		130 (1130): Boost command (BST)			
		131 (1131): Flowrate switch (FS)			
		132 (1132): Filter clogging reverse rotation command (FRC)			
		133 (1133): Switch PID channel (PID2/1)			
		149 (1149): Switch pump control (PCHG)			
		150 (1150): Enable master motor drive in mutual operation (MENO)			
		151 (1151): Pump control motor 1 (MEN1)			
		152 (1152): Pump control motor 2 (MEN2)			
		153 (1153): Pump control motor 3 (MEN3)			
		154 (1154): Pump control motor 4 (MEN4)			
		155 (1155): Pump control motor 5 (MEN5)			
		156 (1156): Pump control motor 6 (MEN6)			
		157 (1157): Pump control motor 7 (MEN7)			
		158 (1158): Pump control motor 8 (MEN8)			
		171 (1171): PID multistep command (PID-SS1)			
		172 (1172): PID multistep command (PID-SS2)			
		181 (1181): External PID multistep command (EPID-SS1)			
		182 (1182): External PID multistep command (EPID-SS2)			
		190 (1190): Cancel timer (TMC)			
		191 (1191): Enable timer 1 (TM1)			
		192 (1192): Enable timer 2 (TM2)			
		193 (1193): Enable timer 3 (TM3)			
		194 (1194): Enable timer 4 (TM4)			
		201 (1201): External PID control 1 ON command (EPID1-ON)			
		202 (1202): Cancel external PID control 1 (%/EPID1)			
		203 (1203): Switch normal/inverse operation under external PID control 1 (EPID1-IVS)			
		204 (1204): Reset external PID1 integral and differential components (EPID1-RST)			
		205 (1205): Hold external PID1 integral component (EPID1-HLD)			
		211 (1211): External PID control 2 ON command (EPID2-ON)			
		212 (1212): Cancel external PID control 2 (%/EPID2)			
		213 (1213): Switch normal/inverse operation under external PID control 2 (EPID2-IVS)			
		214 (1214): Reset external PID2 integral and differential components (EPID2-RST)			
		215 (1215): Hold external PID2 integral component (EPID2-HLD)			
		221 (1221): External PID control 3 ON command (EPID3-ON)			
		222 (1222): Cancel external PID control 3 (%/EPID3)			
		223 (1223): Switch normal/inverse operation under external PID control 3 (EPID3-IVS)			
		224 (1224): Reset external PID3 integral and differential components (EPID3-RST)			
		225 (1225): Hold external PID3 integral component (EPID3-HLD)			

Code	Name	Data setting range	Change when running	Data copying	Default setting
		8001: Auxiliary frequency command 1 8002: Auxiliary frequency command 2 8003: PID process command 1 8004: PID process command 2 8005: PID feedback value 1 8012: Acceleration/deceleration time ratio setting 8013: Upper limit frequency 8014: Lower limit frequency 8030: PID feedback value 2 8031: Auxiliary input 1 to PID process command 8032: Auxiliary input 2 to PID process command 8033: Flow sensor 8041: External PID process command 1 8042: External PID feedback value 1 8043: External PID manual command 1 8044: External PID process command 2 8045: External PID feedback value 2 8046: External PID manual command 2 8047: External PID process command 3 8048: External PID feedback value 3 8049: External PID manual command 3 Setting the value of 1000s in parentheses () shown above assigns a negative logic input to a terminal.			
U91	Customizable Logic Timer Monitor (Step selection)	0: Disable monitoring 1: Step 1 2: Step 2 3: Step 3 4: Step 4 5: Step 5 6: Step 6 7: Step 7 8: Step 8 9: Step 9 10: Step 10 11: Step 11 12: Step 12 13: Step 13 14: Step 14	Y	Y	0
U92	Customizable Logic Calculation Coefficient (Mantissa of calculation coefficient K_{A1})	-9.999 to 9.999	N	Y	0.00
U93	(Exponent of calculation coefficient K_{A1})	-5 to 5	N	Y	0
U94	(Mantissa of calculation coefficient K_{B1})	-9.999 to 9.999	N	Y	0.00
U95	(Exponent of calculation coefficient K_{B1})	-5 to 5	N	Y	0.
U96	(Mantissa of calculation coefficient K_{C1})	-9.999 to 9.999	N	Y	0.00
U97	(Exponent of calculation coefficient K_{C1})	-5 to 5	N	Y	0

U1 codes: Custom Logic Function

Code	Name	Data setting range	Change when running	Data copying	Default setting
U101	Customizable Logic Conversion point 1 (X1)	-999.00 to 0.00 to 9990.00	Y	Y	0.00
U102	(Y1)		Y	Y	0.00
U103	Conversion point 2 (X2)		Y	Y	0.00
U104	(Y2)		Y	Y	0.00
U105	Conversion point 3 (X3)		Y	Y	0.00
U106	(Y3)		Y	Y	0.00
U107	Automatic Calculation of Conversion Coefficients (X3)		0: Disable 1: Execute calculation (Conversion 1)	N	Y

y codes: Link Functions

Code	Name	Data setting range	Change when running	Data copying	Default setting
y01	RS-485 Communication 1 (Station address)	0 to 255 * Set 1 when other than BACnet is 0. * Set 127 when BACnet is 128 or above.	N	Y	1
y02	(Communications error processing)	0: Immediately trip with alarm Er8 1: Trip with alarm Er8 after running for the period specified by timer y03 2: Retry during the period specified by timer y03. If the retry fails, trip with alarm Er8. If it succeeds, continue to run. 3: Continue to run	Y	Y	0
y03	(Timer)	0.0 to 60.0 s	Y	Y	2.0
y04	(Baud rate)	0: 2400 bps 1: 4800 bps 2: 9600 bps 3: 19200 bps 4: 38400 bps	Y	Y	3
y05	(Data length)	0: 8 bits 1: 7 bits	Y	Y	0
y06	(Parity check)	0: None (2 stop bits) 1: Even parity (1 stop bit) 2: Odd parity (1 stop bit) 3: None (1 stop bit)	Y	Y	0
y07	(Stop bits)	0: 2 bits 1: 1 bit	Y	Y	0
y08	(No-response error detection time)	OFF: No detection, 1 to 60 s	Y	Y	OFF
y09	(Response interval)	0.00 to 1.00 s	Y	Y	0.01
y10	(Protocol selection)	0: Modbus RTU protocol 1: SX protocol (loader protocol) 2: Fuji general-purpose inverter protocol 3: Metasys N2 protocol 5: BACnet protocol	Y	Y	1
y11	RS-485 Communication 2 (Station address)	0 to 255	N	Y	1
y12	(Communications error processing)	0: Immediately trip with alarm ErP 1: Trip with alarm ErP after running for the period specified by timer y13 2: Retry during the period specified by timer y13. If the retry fails, trip with alarm ErP. If it succeeds, continue to run. 3: Continue to run	Y	Y	0
y13	(Timer)	0.0 to 60.0 s	Y	Y	2.0
y14	(Baud rate)	0: 2400 bps 1: 4800 bps 2: 9600 bps 3: 19200 bps 4: 38400 bps	Y	Y	3
y15	(Data length)	0: 8 bits 1: 7 bits	Y	Y	0
y16	(Parity check)	0: None (2 stop bits) 1: Even parity (1 stop bit) 2: Odd parity (1 stop bit) 3: None (1 stop bit)	Y	Y	0
y17	(Stop bits)	0: 2 bits 1: 1 bit	Y	Y	0
y18	(No-response error detection time)	OFF: No detection, 1 to 60 s	Y	Y	OFF
y19	(Response interval)	0.00 to 1.00 s	Y	Y	0.01
y20	(Protocol selection)	0: Modbus RTU protocol 1: SX protocol (loader protocol) 2: Fuji general-purpose inverter protocol 3: Metasys N2 protocol 5: BACnet protocol 50: Communications link pump control protocol	Y	Y	0
y95	Data Clear Processing for Communications Error	0: Do not clear the data of function codes Sxx when a communications error occurs. (compatible with the conventional inverters) 1: Clear the data of function codes S01/S05/S19 when a communications error occurs. 2: Clear the run command assigned bit of function code S06 when a communications error occurs. 3: Clear both data of S01/S05/S19 and run command assigned bit of S06 when a communications error occurs. * Related alarms: Er8, ErP, Er4, Er5, ErU	Y	Y	0

Code	Name	Data setting range	Change when running	Data copying	Default setting	
y98	Bus Link Function (Mode selection)	Frequency command 0: Follow H30 data 1: Via fieldbus option 2: Follow H30 data 3: Via fieldbus option	Run command Follow H30 data Follow H30 data Via fieldbus option Via fieldbus option	Y	Y	0
y99	Loader Link Function (Mode selection)	Frequency command 0: Follow H30 and y98 data 1: Via RS-485 link (FRENIC Loader) 2: Follow H30 and y98 data 3: Via RS-485 link (FRENIC Loader)	Run command Follow H30 and y98 data Follow H30 and y98 data Via RS-485 link (FRENIC Loader) Via RS-485 link (FRENIC Loader)	Y	N	0

T codes: Timer Functions

Code	Name	Data setting range	Change when running	Data copying	Default setting
T01	Timer 1 Operation (Operating mode)	0: Disable 1: Enable (Run inverter) 2: Enable (Output digital signal) 3: Enable (Run inverter + Output digital signal)	N	Y	0
T02	(Start time)	Possible to specify in the special menu.	N	Y	0
T03	(End time)	Possible to specify in the special menu.	N	Y	0
T04	(Start day of the week)	Possible to specify in the special menu.	N	Y	0
T06	Timer 2 Operation (Operating mode)	Same as T01.	N	Y	0
T07	(Start time)	Possible to specify in the special menu.	N	Y	0
T08	(End time)	Possible to specify in the special menu.	N	Y	0
T09	(Start day of the week)	Possible to specify in the special menu.	N	Y	0
T11	Timer 3 Operation (Operating mode)	Same as T01.	N	Y	0
T12	(Start time)	Possible to specify in the special menu.	N	Y	0
T13	(End time)	Possible to specify in the special menu.	N	Y	0
T14	(Start day of the week)	Possible to specify in the special menu.	N	Y	0
T16	Timer 4 Operation (Operating mode)	Same as T01.	N	Y	0
T17	(Start time)	Possible to specify in the special menu.	N	Y	0
T18	(End time)	Possible to specify in the special menu.	N	Y	0
T19	(Start day of the week)	Possible to specify in the special menu.	N	Y	0
T51	Timer Operation (Pause date 1)	Possible to specify in the special menu.	N	Y	2210H
T52	(Pause date 2)		N	Y	2210H
T53	(Pause date 3)		N	Y	2210H
T54	(Pause date 4)		N	Y	2210H
T55	(Pause date 5)		N	Y	2210H
T56	(Pause date 6)		N	Y	2210H
T57	(Pause date 7)		N	Y	2210H
T58	(Pause date 8)		N	Y	2210H
T59	(Pause date 9)		N	Y	2210H
T60	(Pause date 10)		N	Y	2210H
T61	(Pause date 11)		N	Y	2210H
T62	(Pause date 12)		N	Y	2210H
T63	(Pause date 13)		N	Y	2210H
T64	(Pause date 14)		N	Y	2210H
T65	(Pause date 15)		N	Y	2210H
T66	(Pause date 16)		N	Y	2210H
T67	(Pause date 17)		N	Y	2210H
T68	(Pause date 18)		N	Y	2210H
T69	(Pause date 19)		N	Y	2210H
T70	(Pause date 20)		N	Y	2210H

K codes: Keypad Functions

Code	Name	Data setting range	Change when running	Data copying	Default setting
K01	LCD Monitor (Language selection)	0: Japanese 1: English 2: German 3: French 4: Spanish 5: Italian 6: Chinese 8: Russian (Available soon) 9: Greek (Available soon) 10: Turkish (Available soon) 11: Polish 12: Czech 13: Swedish 14: Portuguese (Available soon) 15: Dutch (Available soon) 16: Malay 17: Vietnamese (Available soon) 18: Thai (Available soon) 19: Indonesian (Available soon) 100: User-customized language (Available soon)	Y	Y	E/A:1 C:6
K02	Backlight OFF Time	OFF: Always OFF 1 to 30 min.: Automatic OFF time	Y	Y	5
K03	LCD Monitor (Backlight brightness control)	0 (Dark) to 10 (Light)	Y	Y	5
K04	(Contrast control)	0 (Light) to 10 (Dark)	Y	Y	5
K08	LCD Monitor Status Display/Hide Selection	0: Hide 1: Display	Y	Y	1
K10	Main Monitor (Display item selection)	0: Speed monitor (select by K11) 13: Output current 14: Output voltage 18: Calculated torque 19: Input power 25: Load factor 26: Motor output 27: Analog input monitor in physical quantity 35: Input watt-hour (The unit depends on K31.) 50: PID command (final) in physical quantity 51: PID feedback amount (final) in physical quantity 52: PID output 53: PID control 1 command in physical quantity 54: PID control 1 feedback amount in physical quantity 55: PID control 2 command in physical quantity 56: PID control 2 feedback amount in physical quantity 60: External PID control 1 command (final) in physical quantity 61: External PID control 1 feedback amount (final) in physical quantity 62: External PID control 1 output in % 63: External PID control 1 manual command in % 64: External PID control 1 command in physical quantity 65: External PID control 1 feedback amount in physical quantity 70: External PID control 2 command in physical quantity 71: External PID control 2 feedback amount in physical quantity 72: External PID control 2 output in % 73: External PID control 2 manual command in % 80: External PID control 3 command in physical quantity 81: External PID control 3 feedback amount in physical quantity 82: External PID control 3 output in % 83: External PID control 3 manual command in %	Y	Y	0
K11	Main Monitor (Speed monitor item)	1: Output frequency 1 (before slip compensation) 2: Output frequency 2 (after slip compensation) 3: Reference frequency 4: Motor speed in r/min 5: Load shaft speed in r/min 8: Display speed in %	Y	Y	1

Note: Alphabets in the Default setting field denote shipping destination: E (EU), A (Asia), C (China).

Code	Name	Data setting range	Change when running	Data copying	Default setting
K12	Main Monitor (Display when stopped)	0: Reference value 1: Output value	Y	Y	0
K15	Sub Monitor (Display type)	0: Numeric values 1: Bar charts	Y	Y	0
K16	Sub Monitor 1 (Display item selection)	*Refer to K10 (= 13 to 83) and K11 (= 1 to 8).	Y	Y	13
K17	Sub Monitor 2 (Display item selection)		Y	Y	19
K20	Bar Chart 1 (Display item selection)	1: Output frequency 1 (before slip compensation)	Y	Y	1
K21	Bar Chart 2 (Display item selection)	13: Output current 14: Output voltage	Y	Y	13
K22	Bar Chart 3 (Display item selection)	18: Calculated torque 19: Input power 25: Load factor 26: Motor output	Y	Y	19
K29	Display Filter	0.0 to 5.0 s	Y	Y	0.5
K30	Coefficient for Speed Indication	0.01 to 200.00	Y	Y	30.00
K31	Display Unit for Input Watt-hour Data	0: kWh 1: MWh	Y	Y	0
K32	Display Coefficient for Input Watt-hour Data	OFF: Cancel or reset 0.001 to 9999.000	Y	Y	0.010
K33	Long-term, Input Watt-hour Data Monitor	OFF: Cancel or reset 1: Hourly 2: Daily 3: Weekly 4: Monthly	Y	Y	4
K81	Date Format	0: Y/M/D (year/month/day) 1: D/M/Y (day/month/year) 2: M/D/Y (month/day/year) 3: MD, Y (Month day, year)	Y	Y	E/A: 1 C: 0
K82	Time Format	0: 24-hour format (Time : Minute : Second) 1: 12-hour format (Time : Minute : Second AM/PM) 2: 12-hour format (AM/PM Time : Minute : Second)	Y	Y	0
K83	Daylight Saving Time (Summer time)	0: Disable 1: Enable (+ 1 hour) 2: Enable (+ 30 minutes)	Y	Y	0
K84	(Start date)	Possible to specify in the special menu.	Y	Y	0800H
K85	(End date)		Y	Y	0800H
K91	Shortcut Key Function for (◀) in Running Mode (Selection screen)	0: OFF (Disable) 11 to 99	Y	Y	OFF
K92	Shortcut Key Function for (▶) in Running Mode (Selection screen)	0: OFF (Disable) 11 to 99	Y	Y	64

Note: Alphabets in the Default setting field denote shipping destination: E (EU), A (Asia), C (China).

o codes: Option Functions

Code	Name	Data setting range	Change when running	Data copying	Default setting
o01	Terminal [Y6A/B/C] Function (Relay output)	Same as E20.	N	Y	10
o02	Terminal [Y7A/B/C] Function		N	Y	6
o03	Terminal [Y8A/B/C] Function		N	Y	25
o04	Terminal [Y9A/B/C] Function		N	Y	26
o05	Terminal [Y10A/B/C] Function		N	Y	28
o06	Terminal [Y11A/B/C] Function		N	Y	36
o07	Terminal [Y12A/B/C] Function		N	Y	37
o09	Pt Channel (Display unit)	<u>Temperature</u> 60: K 61: °C 62: °F	Y	Y	61
o10	Pt Channel 1 (Sensor type)	0: Jpt100 1: Pt100 2: Ni100 3: Pt1000 4: Ni1000	Y	Y	0
o11	(Extended functions)	0: No extended function assigned 5: PID feedback value 1 30: PID feedback value 2 42: External PID feedback value 1 45: External PID feedback value 2 48: External PID feedback value 3	N	Y	0
o12	(Filter)	0.00 to 100.0 s	Y	Y	1.0
o15	Pt Channel 2 (Sensor type)	Same as o10.	N	Y	0
o16	(Extended functions)	Same as o11.	N	Y	0
o17	(Filter)	Same as o12.	Y	Y	1.0
o27	Communications Error Processing	0: Immediately trip with alarm Er5 1: Run for the period specified by timer o28 and then trip with alarm Er5 2: Retry during the period specified by timer o28. If the retry fails, immediately trip with alarm Er5. 3: Continue to run. After recovery from the error, run according to communications command 4 to 9: Same as o27 = 0. 10: Decelerate to a stop and trip with alarm Er5 11: Run for the period specified by timer o28, decelerate to a stop, and then trip with alarm Er5 12: Retry during the period specified by timer o28. If the retry fails, decelerate to a stop. If it succeeds, continue to run according to communications command 13 to 15: Same as when o27 = 3.	Y	Y	0
o28	(Timer)	0.0 to 60.0 s	Y	Y	0.0
o30	Bus configuration parameter 01	0 to 255 Functions of o30 to o39 differ depending upon the bus option type. For details, refer to the instruction manual of each bus option.	N	Y	0
o31	Bus configuration parameter 02	Same as o30.	N	Y	0
o32	Bus configuration parameter 03		N	Y	0
o33	Bus configuration parameter 04		N	Y	0
o34	Bus configuration parameter 05		N	Y	0
o35	Bus configuration parameter 06		N	Y	0
o36	Bus configuration parameter 07		N	Y	0
o37	Bus configuration parameter 08		N	Y	0
o38	Bus configuration parameter 09		N	Y	0
o39	Bus configuration parameter 10		N	Y	0
o40	Function Code Assignment 1 for Write		0, 1 to 65535 0: No assignment Data mapped I/O (write) Whether or not to support the I/O or the number of supports differs depending upon the bus option type. For the data configuration procedure, refer to the instruction manual of each bus option.	N	Y

Code	Name	Data setting range	Change when running	Data copying	Default setting
o41	Function Code Assignment 2 for Write	Same as o40.	N	Y	0
o42	Function Code Assignment 3 for Write		N	Y	0
o43	Function Code Assignment 4 for Write		N	Y	0
o44	Function Code Assignment 5 for Write		N	Y	0
o45	Function Code Assignment 6 for Write		N	Y	0
o46	Function Code Assignment 7 for Write		N	Y	0
o47	Function Code Assignment 8 for Write		N	Y	0
o48	Function Code Assignment 1 for Read	0, 1 to 65535 0: No assignment Data mapped I/O (read) Whether or not to support the I/O or the number of supports differs depending upon the bus option type. For the data configuration procedure, refer to the instruction manual of each bus option.	N	Y	0
o49	Function Code Assignment 2 for Read	Same as o48.	N	Y	0
o50	Function Code Assignment 3 for Read		N	Y	0
o51	Function Code Assignment 4 for Read		N	Y	0
o52	Function Code Assignment 5 for Read		N	Y	0
o53	Function Code Assignment 6 for Read		N	Y	0
o54	Function Code Assignment 7 for Read		N	Y	0
o55	Function Code Assignment 8 for Read		N	Y	0
o56	Function Code Assignment 9 for Read		N	Y	0
o57	Function Code Assignment 10 for Read		N	Y	0
o58	Function Code Assignment 11 for Read		N	Y	0
o59	Function Code Assignment 12 for Read		N	Y	0
o60	Terminal [32] (Function)		Same as E61.	N	Y
o61	(Offset)	-5.0 to 5.0%	Y	Y	0.0
o62	(Gain)	0.00 to 200.00%	Y	Y	100.00
o63	(Filter setting)	0.00 to 5.00 s	Y	Y	0.05
o64	(Gain base point)	0.00 to 100.00%	Y	Y	100.00
o65	(Polarity)	0: Bipolar 1: Unipolar	N	Y	1
o66	(Bias value)	-100.00 to 100.00%	Y	Y	0.00
o67	(Bias base point)	0.00 to 100.00%	Y	Y	0.00
o69	(Display unit)	Same as J105. (Note that the data setting range starts with "1.")	N	Y	2
o70	(Maximum scale)	-999 to 0.00 to 9990	N	Y	100
o71	(Minimum scale)	-999 to 0.00 to 9990	N	Y	0.00
o75	Terminal [C2] (Current range)	0: 4-20 mA 1: 0-20 mA	N	Y	0
o76	(Function)	Same as E61.	N	Y	0
o77	(Offset)	-5.0 to 5.0%	Y	Y	0.0
o78	(Gain)	0.00 to 200.00%	Y	Y	100.00
o79	(Filter time constant)	0.00 to 5.00 s	Y	Y	0.05
o81	(Gain reference point)	0.00 to 100.00%	Y	Y	100.00
o82	(Bias value)	-100.00 to 100.00%	Y	Y	0.00
o83	(Bias base point)	0.00 to 100.00%	Y	Y	0.00
o85	(Display unit)	Same as J105. (Note that the data setting range starts with "1.")	N	Y	2
o86	(Maximum scale)	-999 to 0.00 to 9990	N	Y	100
o87	(Minimum scale)	-999 to 0.00 to 9990	N	Y	0.00
o90	Terminal [Ao/CS2] Function (Function)	Same as F31.	Y	Y	0
o91	(Output gain)	0 to 300%	Y	Y	100
o93	(Polarity)	0: Bipolar 1: Unipolar	N	Y	1
o96	Terminal [CS/CS1] Function (Function)	Same as F31.	Y	Y	0
o97	(Output gain)	0 to 300%	Y	Y	100

Table A Factory Defaults Depending upon Inverter Capacity

Inverter capacity (kW)	Torque boost 1 F09	Auto-restart after momentary power failure (Restart time) H13
0.75	6.5	0.5
1.5	4.9	
2.2	4.5	
3.7	4.1	
5.5	3.4	
7.5	2.7	
11	2.1	1.0
15	1.6	
18.5	1.3	
22	1.1	
30	0.0	1.5
37		
45		
55		
75		2.0
90		
110		2.5
132		
160		4.0
200		
220		5.0
280		
315		
355		
400		
500		
630		
710		

Table B (1) Motor Parameters

■ When "Fuji standard motors, 8-series" or "Other motors" is selected (P99 = 0 or 4)

Motor capacity (kW) P02	Nominal applied motor (kW)	Rated current (A) P03	No-load current (A) P06	%R1 (%) P07	%X (%) P08	Rated slip frequency P12	Starting mode (Auto search delay time 2) H46
0.01 to 0.09	0.06	0.22	0.20	13.79	11.75	1.77	0.5
0.10 to 0.19	0.1	0.35	0.27	12.96	12.67	1.77	
0.20 to 0.39	0.2	0.65	0.53	12.95	12.92	2.33	
0.40 to 0.74	0.4	1.15	0.83	10.20	13.66	2.40	
0.75 to 1.49	0.75	1.80	1.15	8.67	10.76	2.33	
1.50 to 2.19	1.5	3.10	1.51	6.55	11.21	2.00	
2.20 to 3.69	2.2	4.60	2.43	6.48	10.97	1.80	0.6
3.70 to 5.49	3.7	7.50	3.84	5.79	11.25	1.93	0.8
5.50 to 7.49	5.5	11.50	5.50	5.28	14.31	1.40	1.0
7.50 to 10.99	7.5	14.50	6.25	4.50	14.68	1.57	1.2
11.00 to 14.99	11	21.00	8.85	3.78	15.09	1.07	1.3
15.00 to 18.49	15	27.50	10.00	3.25	16.37	1.13	2.0
18.50 to 21.99	18.5	34.00	10.70	2.92	16.58	0.87	
22.00 to 29.99	22	39.00	12.60	2.70	16.00	0.90	
30.00 to 36.99	30	54.00	19.50	2.64	14.96	0.80	2.3
37.00 to 44.99	37	65.00	20.80	2.76	16.41	0.80	2.5
45.00 to 54.99	45	78.00	23.80	2.53	16.16	0.80	2.5
55.00 to 74.99	55	95.00	29.30	2.35	16.20	0.94	2.6
75.00 to 89.99	75	130.0	41.60	1.98	16.89	0.80	2.8
90.00 to 109.99	90	155.0	49.60	1.73	16.03	0.80	3.2
110.00 to 131.99	110	188.0	45.60	1.99	20.86	0.66	3.5
132.00 to 159.99	132	224.0	57.60	1.75	18.90	0.66	4.1
160.00 to 199.99	160	272.0	64.50	1.68	19.73	0.66	4.5
200.00 to 219.99	200	335.0	71.50	1.57	20.02	0.66	4.7
220.00 to 249.99	220	365.0	71.80	1.60	20.90	0.58	4.7
250.00 to 279.99	250	415.0	87.90	1.39	18.88	0.54	5.0
280.00 to 314.99	280	462.0	93.70	1.36	19.18	0.54	5.5
315.00 to 354.99	315	520.0	120.0	0.84	16.68	0.45	5.6
355.00 to 399.99	355	580.0	132.0	0.83	16.40	0.43	5.6
400.00 to 449.99	400	670.0	200.0	0.62	15.67	0.29	7.5
450.00 to 499.99	450	770.0	270.0	0.48	13.03	0.23	9.8
500.00 to 559.99	500	835.0	270.0	0.51	12.38	0.18	9.8
560.00 to 629.99	560	940.0	270.0	0.57	13.94	0.20	9.8
630.00 to 709.99	630	1050.0	355.0	0.46	11.77	0.17	10.5
710.00 or above	710	1150.0	290.0	0.54	14.62	0.21	10.5

Table B (2) Motor Parameters (Continued)

■ When "HP rating motors" is selected (P99 = 1)

Motor capacity (HP) P02	Nominal applied motor (HP)	Rated current (A) P03	No-load current (A) P06	%R1 (%) P07	%X (%) P08	Rated slip frequency P12	Starting mode (Auto search delay time 2) H46
0.01 to 0.11	0.1	0.22	0.20	13.79	11.75	2.50	0.5
0.12 to 0.24	0.12	0.34	0.27	12.96	12.67	2.50	
0.25 to 0.49	0.25	0.70	0.56	11.02	13.84	2.50	
0.50 to 0.99	0.5	1.00	0.61	6.15	8.80	2.50	
1.00 to 1.99	1	1.50	0.77	3.96	8.86	2.50	
2.00 to 2.99	2	2.90	1.40	4.29	7.74	2.50	
3.00 to 4.99	3	4.00	1.79	3.15	20.81	1.17	
5.00 to 7.49	5	6.30	2.39	3.34	23.57	1.50	0.8
7.50 to 9.99	7.5	9.30	3.12	2.65	28.91	1.17	1.0
10.00 to 14.99	10	12.7	4.37	2.43	30.78	1.17	1.2
15.00 to 19.99	15	18.7	6.36	2.07	29.13	1.00	1.3
20.00 to 24.99	20	24.6	4.60	2.09	29.53	1.00	2.0
25.00 to 29.99	25	30.0	8.33	1.75	31.49	1.00	
30.00 to 39.99	30	36.2	9.88	1.90	32.55	1.00	
40.00 to 49.99	40	45.5	6.80	1.82	25.32	0.47	2.3
50.00 to 59.99	50	57.5	9.33	1.92	24.87	0.58	2.5
60.00 to 69.99	60	68.7	10.4	1.29	26.99	0.35	2.5
75.00 to 99.99	75	86.9	14.3	1.37	27.09	0.35	2.6
100.00 to 124.99	100	113.0	18.7	1.08	23.80	0.23	2.8
125.00 to 149.99	125	134.0	14.9	1.05	22.90	0.35	3.2
150.00 to 174.99	150	169.0	45.2	0.96	21.61	0.39	3.5
175.00 to 199.99	175	169.0	45.2	0.96	21.61	0.39	4.1
200.00 to 249.99	200	231.0	81.8	0.72	20.84	0.23	4.5
250.00 to 299.99	250	272.0	41.1	0.71	18.72	0.35	4.7
300.00 to 324.99	300	323.0	45.1	0.53	18.44	0.23	4.7
325.00 to 349.99	325	323.0	45.1	0.53	18.44	0.23	5.0
350.00 to 399.99	350	375.0	68.3	0.99	19.24	0.46	5.5
400.00 to 449.99	400	429.0	80.7	1.11	18.92	0.46	5.6
450.00 to 499.99	450	481.0	85.5	0.95	19.01	0.48	5.6
500.00 to 599.99	500	534.0	99.2	1.05	18.39	0.45	7.5
600.00 to 699.99	600	638.0	140.0	0.85	18.38	0.39	9.8
700.00 to 749.99	700	756.0	140.0	0.85	18.38	0.39	9.8
750.00 to 799.99	750	806.0	164.0	1.02	21.92	0.70	9.8
800.00 to 849.99	800	870.0	144.0	1.15	24.53	0.53	9.8
850.00 to 899.99	850	923.0	209.0	1.17	21.69	0.45	10.5
900.00 or above	900	994.0	172.0	1.34	25.44	0.60	10.5

Chapter 6 TROUBLESHOOTING

Alarm Codes

Table 6.1 Quick List of Alarm Codes

Code	Name	Description
OC1 OC2 OC3	Instantaneous overcurrent	The inverter momentary output current exceeded the overcurrent level. OC1: Overcurrent during acceleration OC2: Overcurrent during deceleration OC3: Overcurrent during running at a constant speed
EF	Ground fault	A ground-fault current flowed from the inverter's output terminals.
OV1 OV2 OV3	Overvoltage	The DC link bus voltage exceeded the overvoltage detection level. OV1: Overvoltage during acceleration OV2: Overvoltage during deceleration OV3: Overvoltage during running at a constant speed
LV	Undervoltage	The DC link bus voltage dropped below the undervoltage detection level.
Lin	Input phase loss	An input phase loss occurred or the Interphase voltage unbalance rate was large.
OPL	Output phase loss	An output phase loss occurred.
OH1	Heat sink overheat	The temperature around the heat sink has risen abnormally.
OH2	External alarm	The external alarm THR was entered. (when the THR "Enable external alarm trip" has been assigned to any digital input terminal)
OH3	Inverter internal overheat	The temperature inside the inverter has exceeded the allowable limit.
OH4	Motor protection (PTC thermistor)	The temperature of the motor has risen abnormally.
FUS	Fuse trip	An internal short-circuit tripped a fuse (110 kW or greater).
PbF	Charging circuit malfunction	No power was supplied to the charging resistance short-circuit electromagnetic contactor (45 kW or greater).
OL1	Overload of motor 1	The electronic thermal protection for motor overload detection was activated.
OLU	Inverter overload	The temperature inside the inverter has risen abnormally.
Er1	Memory error	An error has occurred in writing data to the memory in the inverter.
Er2	Keypad communications error	A communications error has occurred between the keypad and the inverter.
Er3	CPU error	A CPU error or LSI error has occurred.
Er4	Option communications error	A communications error has occurred between the connected option card and the inverter.
Er5	Option error	An error was detected by the connected option card (not by the inverter).
Er6	Operation protection	An incorrect operation was attempted.
Er7	Tuning error	Auto-tuning has failed, resulting in abnormal tuning results.
Er8 ErP	RS-485 communications error (COM port 1) RS-485 communications error (COM port 2)	A communications error has occurred during RS-485 communication.
ErF	Data saving error during undervoltage	When the undervoltage protection was activated, the inverter failed to save data, showing this error.
ErH	Hardware error	The LSI on the power printed circuit board has malfunctioned due to noise, etc.
PV1 PV2 PVA PVb PVC	PID feedback error	The PID feedback signal wire is broken under PID control.
CoF	Current input break detection	A break was detected in the current input.
ECF	Enable circuit failure	The Enable circuit was diagnosed as a circuit failure.
ECL	Customizable logic error	A customizable logic configuration error has caused an alarm.
rLo	Stuck prevention	The inverter failed to start due to overcurrent.
FoL	Filter clogging error	An overload state was detected under PID control.
LoK	Password protection	A wrong password has been entered exceeding the predetermined number of times.
Err	Mock alarm	A mock alarm has been generated intentionally by keypad operation.

Chapter 7 MAINTENANCE AND INSPECTION

Perform daily and periodic inspections to avoid trouble and keep reliable operation of the inverter for a long time.

7.1 Daily Inspection

Visually inspect the inverter for operation errors from the outside without removing the covers when the inverter is ON or operating.

- Check that the expected performance (satisfying the standard specifications) is obtained.
- Check that the surrounding environment satisfies the environmental requirements given in Chapter 8, Section 8.1 "Standard Model."
- Check that the keypad displays normally.
- Check for abnormal noise, odor, or excessive vibration.
- Check for traces of overheat, discoloration and other defects.

7.2 Periodic Inspection

Before starting periodic inspections, be sure to stop the motor, shut down the power, and wait at least 10 minutes. Make sure that the charging lamp is turned OFF. Further, make sure, using a multimeter or a similar instrument, that the DC link bus voltage between the main circuit terminals P(+) and N(-) has dropped to the safe level (+25 VDC or below).

Table 7.1 List of Periodic Inspections

Check part	Check item	How to inspect	Evaluation criteria
Environment	1) Check the ambient temperature, humidity, vibration and atmosphere (dust, gas, oil mist, or water drops). 2) Check that tools or other foreign materials or dangerous objects are not left around the equipment.	1) Check visually or measure using apparatus. 2) Visual inspection	1) The standard specifications must be satisfied. 2) No foreign or dangerous objects are left.
Input voltage	Check that the input voltages of the main and control circuit are correct.	Measure the input voltages using a multimeter or the like.	The standard specifications must be satisfied.
Keypad	1) Check that the display is clear. 2) Check that there is no missing part in the displayed characters.	1), 2) Visual inspection	1), 2) The display can be read and there is no fault.
Structure such as frame and cover	Check for: 1) Abnormal noise or excessive vibration 2) Loose bolts (at clamp sections). 3) Deformation and breakage 4) Discoloration caused by overheat 5) Contamination and accumulation of dust or dirt	1) Visual or auditory inspection 2) Retighten. 3), 4), 5) Visual inspection	1), 2), 3), 4), 5) No abnormalities
Main circuit	Common	1) Retighten. 2), 3) Visual inspection	1), 2), 3) No abnormalities
	Conductors and wires	1), 2) Visual inspection	1), 2) No abnormalities

Table 7.1 List of Periodic Inspections (Continued)

Check part	Check item	How to inspect	Evaluation criteria
Main circuit	Terminal blocks	Check that the terminal blocks are not damaged.	Visual inspection No abnormalities
	DC link bus capacitor	1) Check for electrolyte leakage, discoloration, cracks and swelling of the casing. 2) Check that the safety valve does not protrude remarkably. 3) Measure the capacitance if necessary.	1), 2) Visual inspection 3) Measure the discharge time with capacitance probe. 1), 2) No abnormalities 3) The discharge time should not be shorter than the one specified by the replacement manual.
	Transformer and reactor	Check for abnormal roaring noise and odor.	Auditory, visual, and olfactory inspection No abnormalities
	Magnetic contactor and relay	1) Check for chatters during operation. 2) Check that contact surface is not rough.	1) Auditory inspection 2) Visual inspection 1), 2) No abnormalities
Control circuit	Printed circuit board	1) Check for loose screws and connectors. 2) Check for odor and discoloration. 3) Check for cracks, breakage, deformation and remarkable rust. 4) Check the capacitors for electrolyte leaks and deformation.	1) Retighten. 2) Olfactory and visual inspection 3), 4) Visual inspection 1), 2), 3), 4) No abnormalities
Cooling system	Cooling fan	1) Check for abnormal noise and excessive vibration. 2) Check for loose bolts. 3) Check for discoloration caused by overheat.	1) Auditory and visual inspection, or turn manually (be sure to turn the power OFF). 2) Retighten. 3) Visual inspection 1) Smooth rotation 2), 3) No abnormalities
	Ventilation path	Check the heat sink, intake and exhaust ports for clogging and foreign materials.	Visual inspection No abnormalities

Remove dust accumulating on the inverter with a vacuum cleaner. If the inverter is stained, wipe it off with a chemically neutral cloth.

7.3 List of Periodic Replacement Parts

The inverter consists of many electronic parts including semiconductor devices. Table 7.2 lists replacement parts that should be periodically replaced for preventive maintenance (Use the lifetime judgment function as a guide). These parts are likely to deteriorate with age due to their constitution and properties, leading to the decreased performance or failure of the inverter. When the replacement is necessary, consult IMO.

Table 7.2 Replacement Parts

Part name	Standard replacement intervals (See Notes below.)	
	0.75 to 90kW	110 to 710kW
DC link bus capacitor	5 years	10 years
Electrolytic capacitors on printed circuit boards	5 years	10 years
Cooling fans	5 years	10 years
Fuse	-	10 years

(Notes) • These replacement intervals are based on the inverter's service life estimated at an ambient temperature of 30°C (IP55) or 40°C (IP21) at full load (100% of the inverter rated current). These replacement intervals are based on the inverter's service life estimated at an ambient temperature of 40°C (IP00) and a load factor of 80% of the inverter's rated current. Replacement intervals may be shorter when the ambient temperature exceeds 30°C (IP55) or 40°C (IP00/IP21) or when the inverter is used in an excessively dusty environment.

• Standard replacement intervals mentioned above are only a guide for replacement, not a guaranteed service life.

7.4 Inquiries about Product and Guarantee

7.4.1 When making an inquiry

Upon breakage of the product, uncertainties, failure or inquiries, inform your IMO of the following information.

- 1) Inverter type (Refer to Chapter 1, Section 1.1.)

- 2) SER No. (serial number of the product) (Refer to Chapter 1, Section 1.1.)
- 3) Function codes and their data that you changed (Refer to the JAGUAR VXA User's Manual, Chapter 5, Section 5.6.3.2.)
- 4) ROM version (Refer to JAGUAR VXA User's Manual, Chapter 6.)
- 5) Date of purchase
- 6) Inquiries (for example, point and extent of breakage, uncertainties, failure phenomena and other circumstances)

7.4.2 Product warranty

Terms of IMO 5 year warranty.

- IMO Jaguar Inverters are covered by a 5 year warranty from date of despatch.
- In the event of failure due to faulty components or inferior workmanship, the Inverter will be replaced or repaired free of charge. Warranty replacements and repaired units will be despatched free of charge, all costs related to faulty units being returned to IMO for inspection/repair are the responsibility of the sender.
- In circumstances where it is viable for the Inverter to be repaired in situ due to size (>30kw), an Engineer from IMO or contracted to represent IMO can be supplied. Site visits are chargeable at IMO's current service rate, any warranty parts will be replaced free of charge.
- All Inverters require a Returns Authorisation reference to be supplied with the Inverter upon returning the drive to IMO, this reference can be obtained from our website www.imopconline.com by registering and following the returns instructions.

Warranty restrictions.

- Incorrect, or unsafe installation.
- Poor condition due to abuse, neglect or improper maintenance.
- Modifications, repairs performed by anyone other than IMO or without prior written agreement.
- Inverter used in incorrect application or used for function other than for which it is designed.
- Any alterations, which may invalidate the Inverters CE declaration.
- Non IMO options or ancillary devices used.

Liability.

- Regardless whether a breakdown occurs during or after the warranty period, IMO shall not be liable for any loss of opportunity, loss of profits, penalty clauses or damages arising from any special circumstances, secondary damages, accident compensation to another company, damages to any equipment, or personal injury.

Chapter 8 SPECIFICATIONS

8.1 Standard Model

Three-phase 400 V class series (0.75 to 37 kW)

Item		Specifications												
Type: (VXH---#**4E) (*1)		2A5	4A1	5A5	9	13A5	18A5	24A5	32	39	45	60	75	
Nominal applied motor (kW) (*2)		0.75	1.5	2.2	4.0	5.5	7.5	11	15	18.5	22	30	37	
Output ratings	Rated capacity (kVA) (*9)	1.9	3.1	4.1	6.8	10	14	18	24	29	34	45	57	
	Rated capacity (kW)	0.75	1.5	2.2	4.0	5.5	7.5	11	15	18.5	22	30	37	
	Voltage (V) (*10)	3-phase, 380 to 480 V (with AVR function)												
Rated current (A) (*3)		2.5	4.1	5.5	9.0	13.5	18.5	24.5	32	39	45	60	75	
Overload capability		110%-1 min (Overload interval: Compliant with IEC/EN 61800-2)												
Input power	Main power supply (number of phases, voltage, frequency)	3-phase, 380 to 480 V, 50/60 Hz												
	Auxiliary control power supply input (number of phases, voltage, frequency)	Single-phase, 380 to 480 V, 50/60 Hz												
	Allowable voltage/frequency	Voltage: +10 to -15% (Interphase voltage unbalance: 2% or less) (*6), Frequency: +5 to -5%												
	Rated current (A) (*4)	1.6	3.0	4.3	7.4	10.3	13.9	20.7	27.9	34.5	41.1	55.7	69.4	
Required capacity (kVA)		1.2	2.1	3.0	5.2	7.2	9.7	15	20	24	29	39	49	
Braking	Braking torque [%] (*11)	20										10 to 15		
	DC braking	Braking start frequency: 0.0 to 60.0 Hz; braking time: 0.0 to 30.0 s; braking operation level: 0 to 60%												
EMC filter (IEC/EN 61800-3: 2004)		Compliant with EMC Directives, Emission and Immunity: Category C2 (2nd Env.)												
DC reactor (DCR)		Built-in (IEC/EN 61000-3-2, IEC/EN 61000-3-12)												
Power factor (at the rated load)	Fundamental wave power factor	> 0.98												
	Total power factor	≥ 0.90												
Efficiency (at the rated load) (%)		95	96	96	96	97	97	97	97	97	97	97	97	
Safety standard compliance		UL508C, C22.2 No. 14 (pending), IEC/EN 61800-5-1:2007												
Enclosure (IEC/EN 60529)		IP21/IP55												
Cooling method		Fan cooling												
Weight / Mass (kg)	IP21	10	10	10	10	10	10	18	18	18	18	23	23	
	IP55	10	10	10	10	10	10	18	18	18	18	23	23	
Environmental Requirements	Site location	Indoors												
	Ambient temperature	IP00/IP21	-10 to +50°C											
		IP55	-10 to +40°C											
	Relative humidity	5 to 95% (No condensation)												
	Atmosphere	The inverter must not be exposed to dust, direct sunlight, corrosive gases, flammable gases, oil mist, vapor or water drops. Pollution degree 2 (IEC/EN 60664-1) (*7) The atmosphere can contain a small amount of salt. (0.01 mg/cm ² or less per year) The inverter must not be subjected to sudden changes in temperature that will cause condensation to form.												
	Altitude	1,000 m max. (*8)												
	Atmospheric pressure	86 to 106 kPa												
Vibration		3 mm				2 to less than 9 Hz								
		10 m/s ²				9 to less than 200 Hz								

(*1) # Enclosure: M (IP21) or L (IP55).

(*2) 4-pole standard motor.

(*3) When running the inverter at the carrier frequency 4 kHz or above, it is necessary to derate the current rating.

(*4) When the inverter is connected to the power supply of 400 V, 50 Hz, Rsc = 120.

(*5) 4.0 kW for the EU.

(*6)
$$\text{Voltage unbalance (\%)} = \frac{\text{Max. voltage (V)} - \text{Min. voltage (V)}}{\text{Three-phase average voltage (V)}} \times 67 \text{ (IEC/EN 61800-3)}$$

If this value is 2 to 3%, use an optional AC reactor (ACR). *Applies to all models, regardless of capacity. Even if the voltage drops down to -20%, the inverter can run (operation guaranteed) provided that the load current is within the inverter rated current range. *Applies only to models with a capacity of 37 kW or less.

(*7) Do not install the inverter in an environment where it may be exposed to lint, cotton waste or moist dust or dirt which will clog the heat sink of the inverter. If the inverter is to be used in such an environment, install it in a dustproof panel of your system.

(*8) If you use the inverter in an altitude above 1000 m, you should apply an output current derating factor as listed in the table below.

Altitude	1000 m or lower	1000 to 1500 m	1500 to 2000 m	2000 to 2500 m	2500 to 3000 m
Output current derating factor	1.00	0.97	0.95	0.91	0.88

(*9) Applies to inverters with a rated capacity of 440 V.

(*10) The inverter cannot output a voltage higher than the supply voltage.

(*11) Indicates average braking torque value for motor alone (varies with motor efficiency).

(45 to 710 kW)

Item		Specifications																
Type Type: (VXH--##*4E) (*1)		91	112	150	176	210	253	304	377	415	520	585	650	740	960	1170	1370	
Nominal applied motor (kW) (*2)		45	55	75	90	110	132	160	200	220	280	315	355	400	500	630	710	
Output ratings	Rated capacity (kVA) (*9)	69	85	114	134	160	193	231	287	316	396	445	495	563	731	891	1044	
	Rated capacity (kW)	45	55	75	90	110	132	160	200	220	280	315	355	400	500	630	710	
	Voltage (V) (*10)	3-phase, 380 to 480 V (with AVR function)																
	Rated current (A) (*3)	91	112	150	176	210	253	304	377	415	520	585	650	740	960	1170	1370	
	Overload capability	110%-1 min (Overload interval: Compliant with IEC/EN 61800-2)																
Input power	Main power supply (number of phases, voltage, frequency)	3-phase, 380 to 440 V, 50 Hz 3-phase, 380 to 480 V, 60 Hz																
	Auxiliary control power supply input (number of phases, voltage, frequency)	Single-phase, 380 to 480 V, 50/60 Hz																
	Auxiliary main power supply input (number of phases, voltage, frequency) (*5)	Single -phase, 380 to 440 V, 50 Hz Single -phase, 380 to 480 V, 60 Hz																
	Allowable voltage/frequency	Voltage: +10 to -15% (Interphase voltage unbalance: 2% or less) (*6), Frequency: +5 to -5%																
	Rated current (A) (*4)	83.1	102	136	162	201	238	286	357	390	500	559	628	705	881	1115	1256	
	Required capacity (kVA)	58	71	95	113	140	165	199	248	271	347	388	436	489	611	773	871	
Braking	Braking torque [%] (*11)	10 to 15																
	DC braking	Braking start frequency: 0.0 to 60.0 Hz; braking time: 0.0 to 30.0 s; braking operation level: 0 to 60%																
EMC filter (IEC/EN 61800-3: 2004)		C2/2nd.				Compliant with EMC Directives, Emission and Immunity: Category C3 (2nd Env.)												
DC reactor (DCR)		Built-in				Standard accessory												
Power factor (at the rated load)	Fundamental wave power factor	> 0.98																
	Total power factor	≥ 0.90																
Efficiency (at the rated load) (%)		97	97	97	97	97	97	98	98	98	98	98	98	98	98	98	98	
Safety standard compliance		UL508C, C22.2 No. 14 (pending), IEC/EN 61800-5-1:2007																
Enclosure (IEC/EN 60529)		IP21/IP55				IP00												
Cooling method		Fan cooling																
Weight / Mass (kg)	IP21	50	50	70	70	-												
	IP55	50	50	70	70	-												
	IP00	-				62	64	94	98	129	140	245	245	245	330	530	530	
Environmental Requirements	Site location	Indoors																
	Ambient temperature	IP00/IP21	-10 to +50°C															
		IP55	-10 to +40°C															
	Relative humidity	5 to 95% (No condensation)																
	Atmosphere	The inverter must not be exposed to dust, direct sunlight, corrosive gases, flammable gases, oil mist, vapor or water drops. Pollution degree 2 (IEC/EN 60664-1) (*7) The atmosphere can contain a small amount of salt. (0.01 mg/cm ² or less per year) The inverter must not be subjected to sudden changes in temperature that will cause condensation to form.																
	Altitude	1,000 m max. (*8)																
	Atmospheric pressure	86 to 106 kPa																
	Vibration	3 mm 2 to 9 Hz 10 m/s ² 9 to less than 200 Hz						3 mm 2 to less than 9 Hz 2 m/s ² 20 to less than 55 Hz 1 m/s ² 55 to less than 200 Hz										

(*1) # Enclosure: S (IP00), M (IP21) or L (IP55)

(*2) 4-pole standard motor

(*3) Current must be reduced for inverters with a capacity of 90 kW or less when operated at a carrier frequency of 4 kHz or greater. Similarly, current must be reduced for inverters with a capacity of 110 kW or greater when operated at a carrier frequency of 5 kHz or greater.

(*4) When the inverter is connected to the power supply of 400 V, 50 Hz, Rsce = 120.

(*5) If using inverters with DC power input, supply AC power to the internal circuits.

(*6)
$$\text{Voltage unbalance (\%)} = \frac{\text{Max. voltage (V)} - \text{Min. voltage (V)}}{\text{Three - phase average voltage (V)}} \times 67 \text{ (IEC/EN 61800 - 3)}$$

If this value is 2 to 3%, use an optional AC reactor (ACR).

(*7) Do not install the inverter in an environment where it may be exposed to lint, cotton waste or moist dust or dirt which will clog the heat sink of the inverter. If the inverter is to be used in such an environment, install it in a dustproof panel of your system.

(*8) If you use the inverter in an altitude above 1000 m, you should apply an output current derating factor as listed in the table below.

Altitude	1000 m or lower	1000 to 1500 m	1500 to 2000 m	2000 to 2500 m	2500 to 3000 m
Output current derating factor	1.00	0.97	0.95	0.91	0.88

(*9) Applies to inverters with a rated capacity of 440 V.

(*10) The inverter cannot output a voltage higher than the supply voltage.

(*11) Indicates average braking torque value for motor alone (varies with motor efficiency).

External Dimensions

VXA2A5*** to VXA18A5***

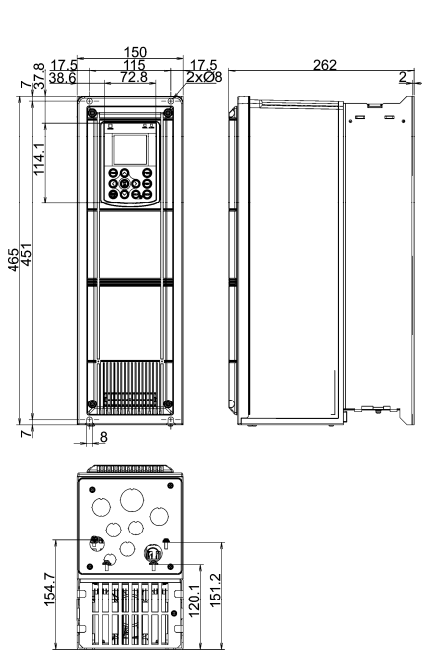

VXA24A5*** to VXA45***

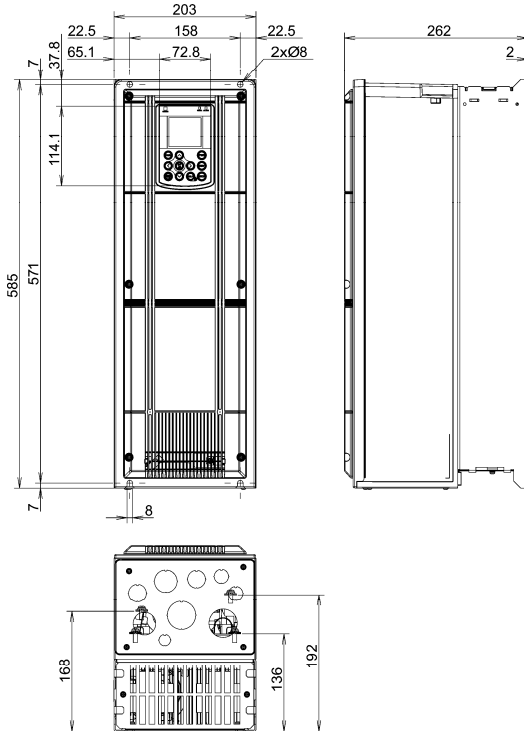

VXA60*** to VXA75***

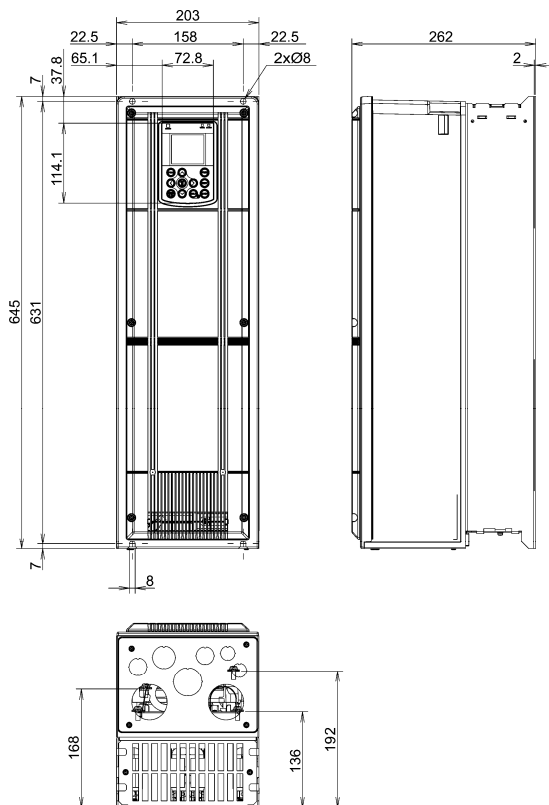

VXA91*** to VXA112***

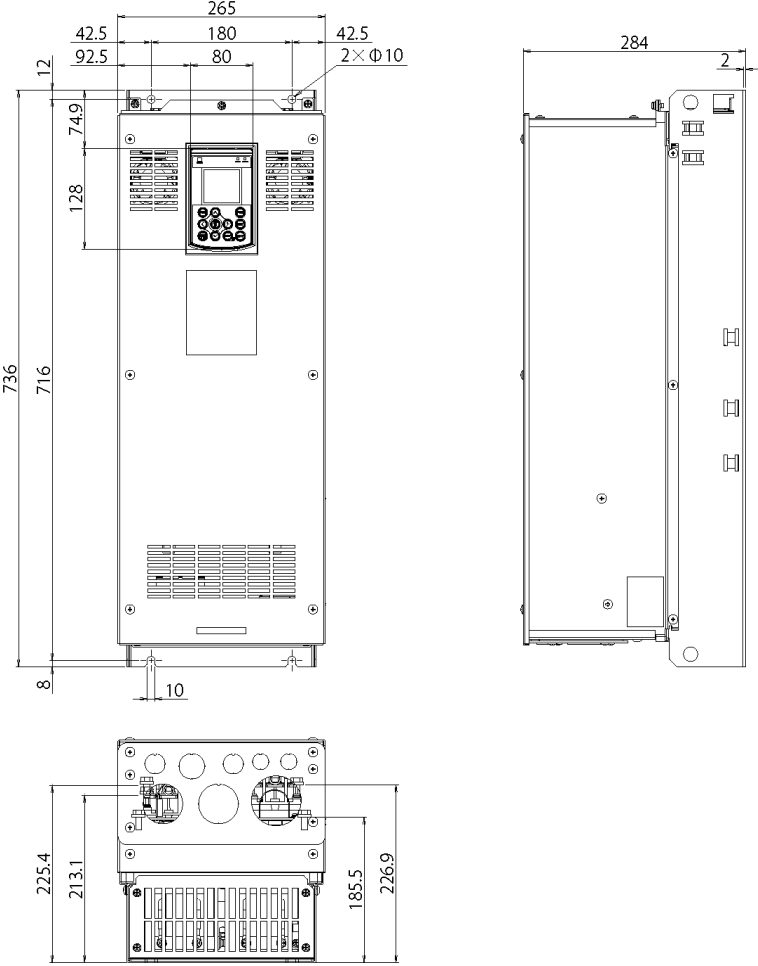

VXA150*** to VXA176***

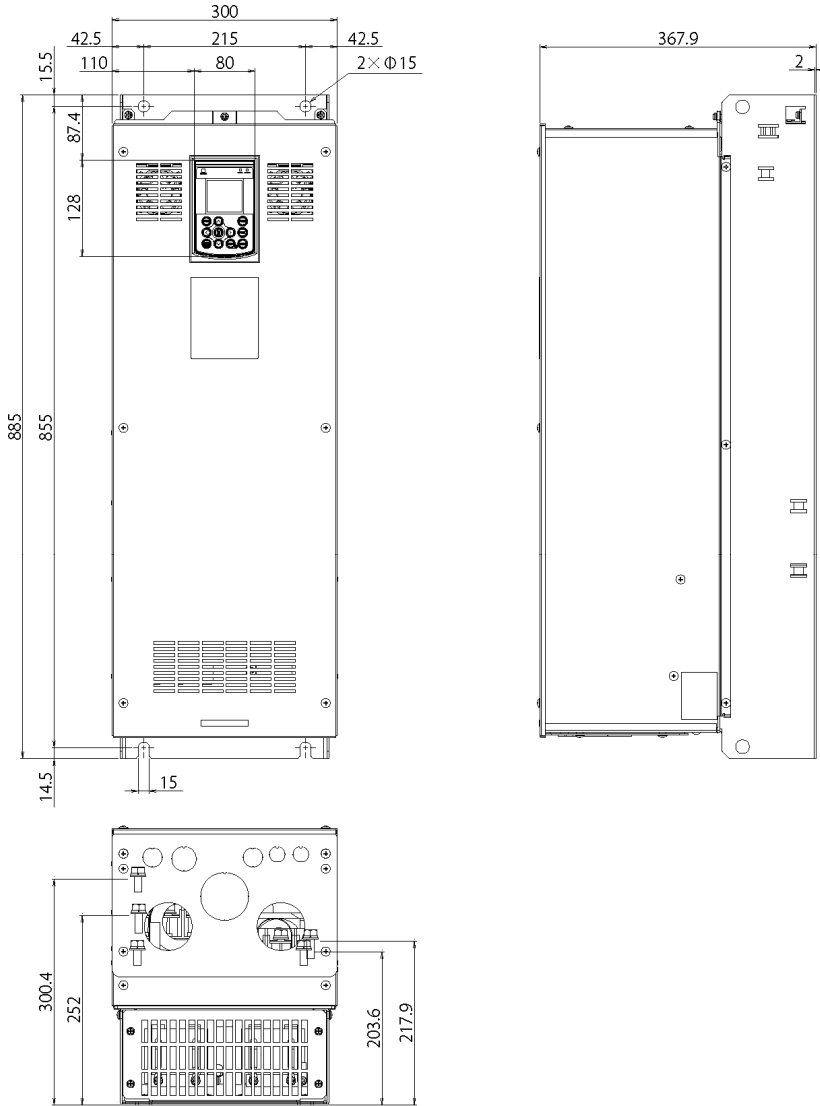

VXA210S-4E, VXS253S-4E

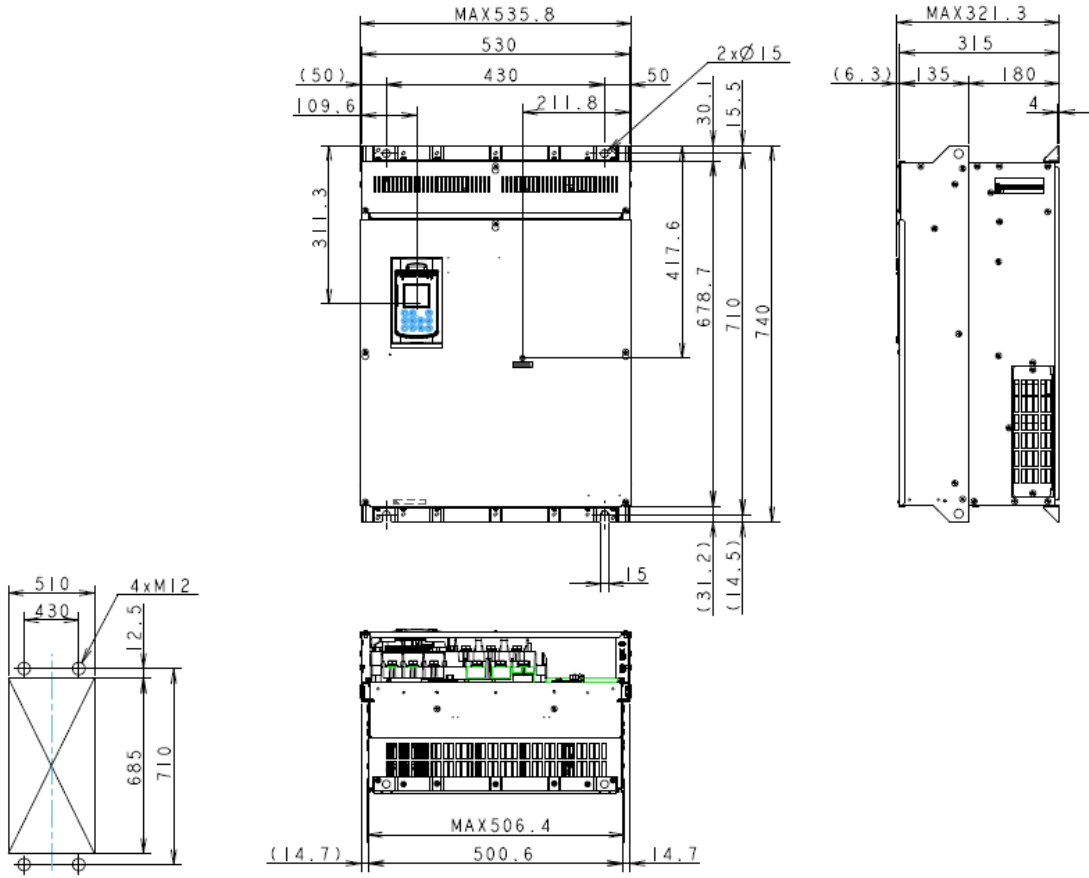

VXA304S-4E, VXA377S-4E

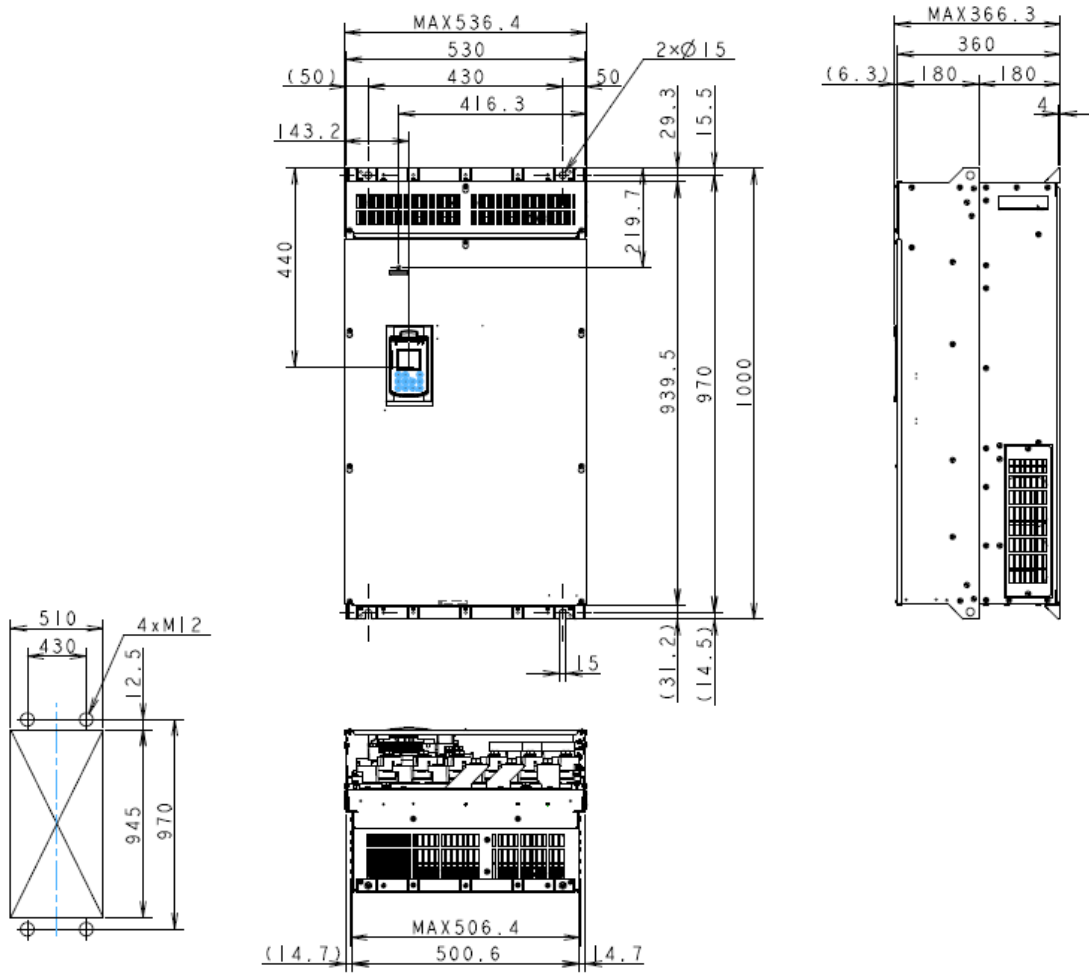

VXA415S-4E, VXA520S-4E

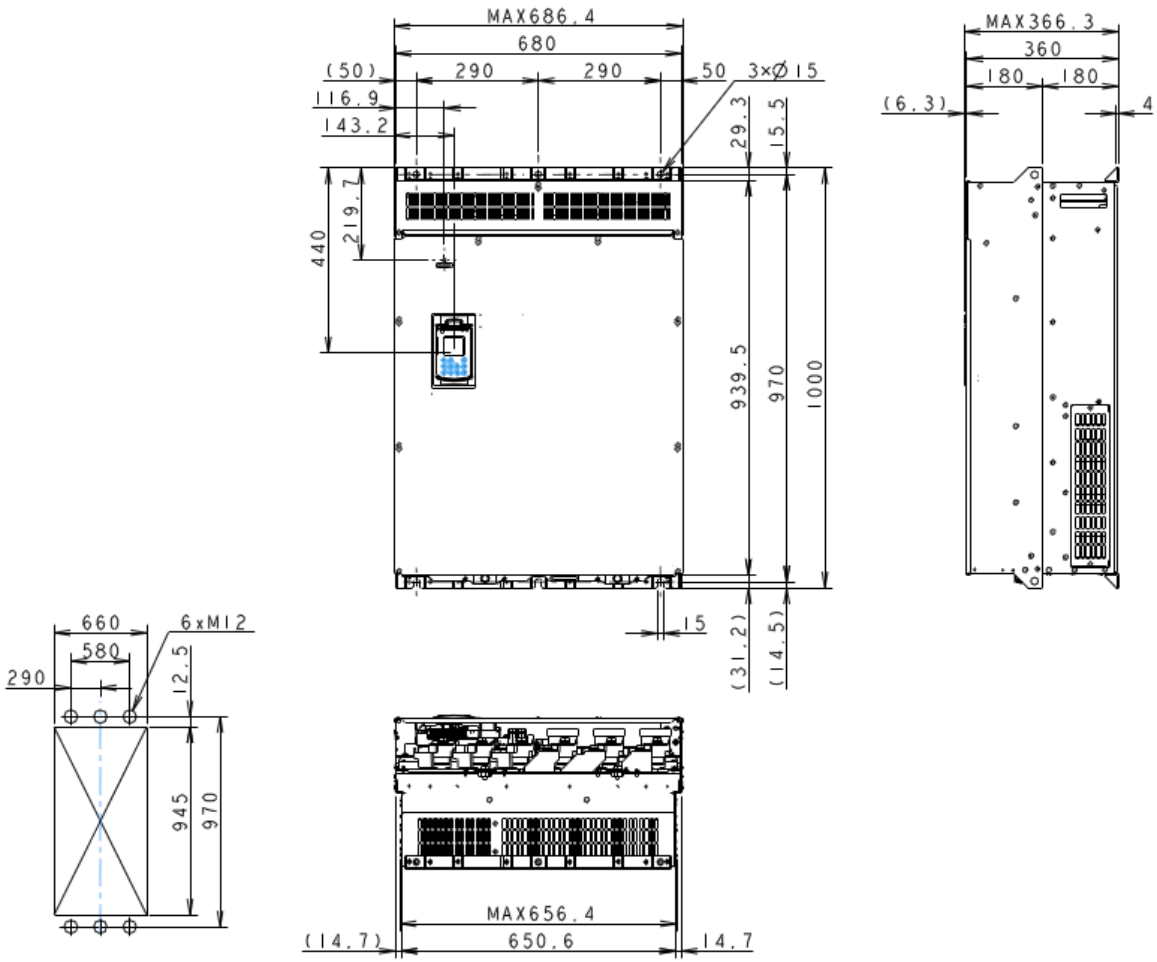

VXA585S-4E, VXA650S-4E, VXA740S-4E

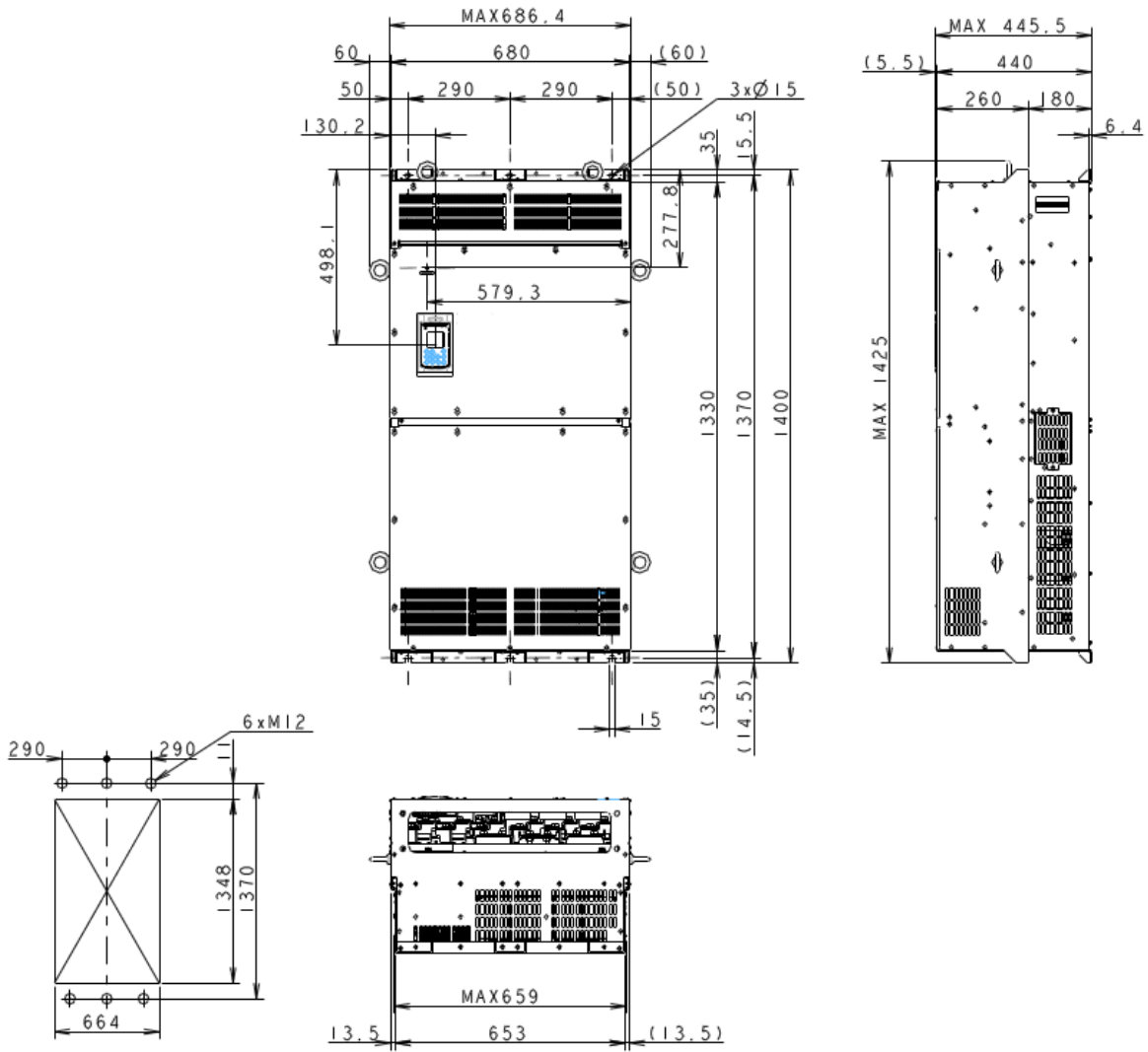

VXA960S-4E

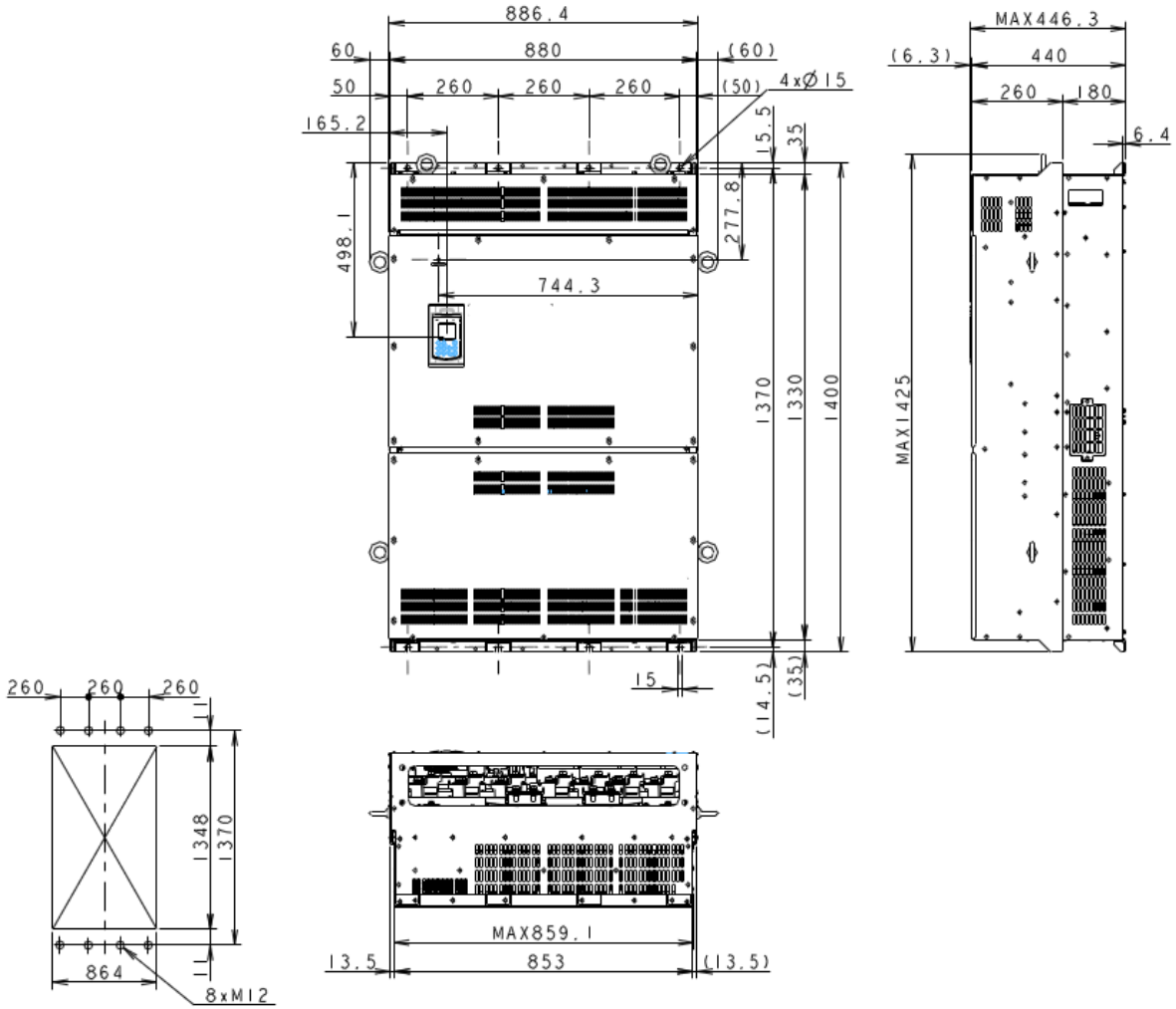

VXA1170S-4E, VXA1370S-4E

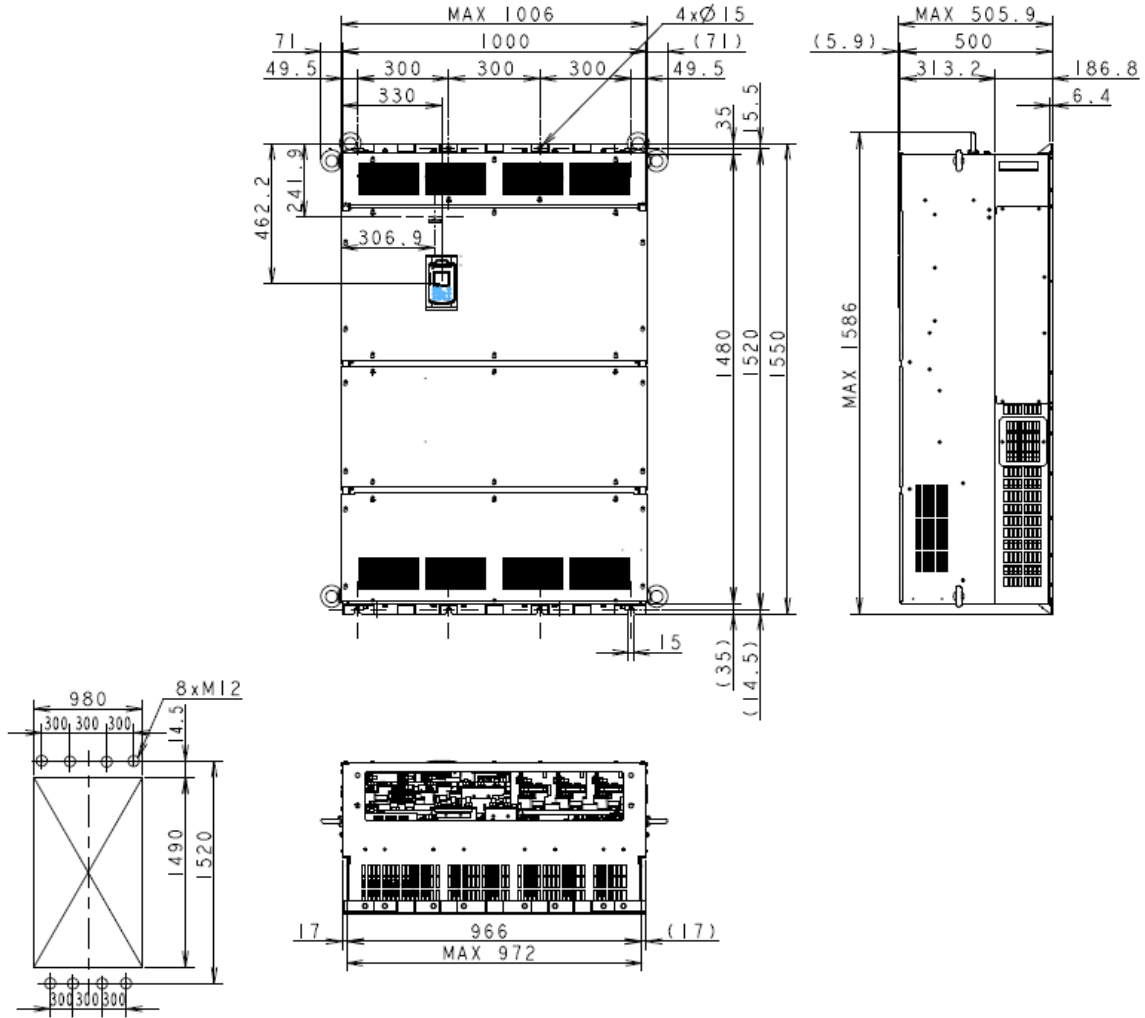

Keypad

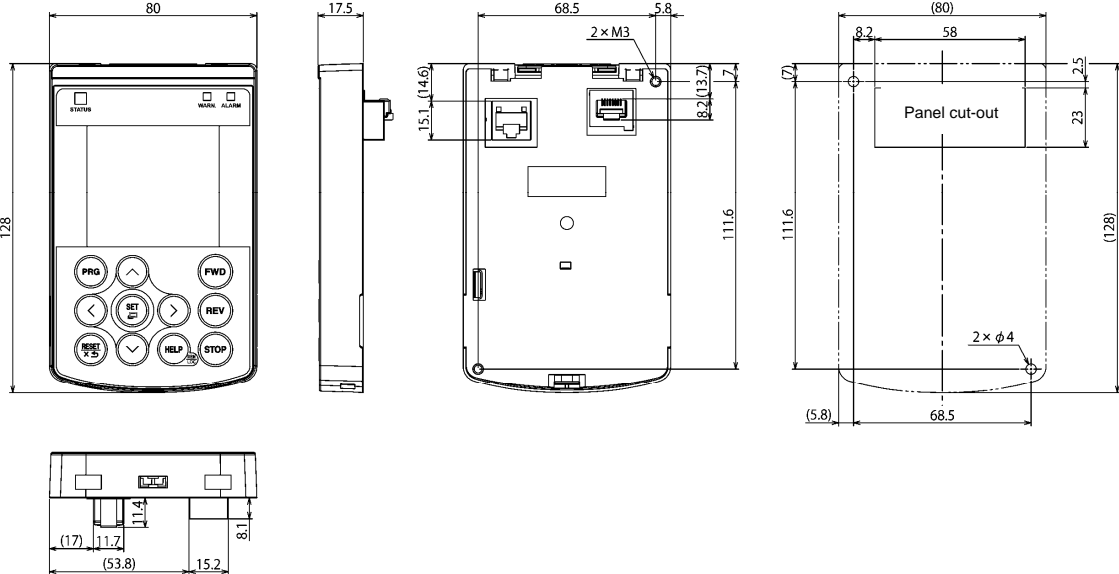

Chapter 9 CONFORMITY WITH STANDARDS

9.1 Compliance with European Standards

The CE marking on IMO products indicates that they comply with the essential requirements of the Electromagnetic Compatibility (EMC) Directive 2004/108/EC and Low Voltage Directive 2006/95/EC which are issued by the Council of the European Communities.

The products comply with the following standards

Table 9.1 Standalone Standard Compliance

	VXA2A5#-4E to VXA176#-4E	VXA210S-4E to VXA1370S-4E
Low Voltage Directive	IEC/EN 61800-5-1: 2007	
EMC Directives	IEC/EN 61800-3: 2004	
Immunity	Second environment (Industrial)	
Emission	Category C2	Category C3

Table 9.2 Standard Compliance When Used with an EMC Filter

Inverter alone	VXA210S-4E to VXA520S-4E	VXA585S-4E to VXA1370S-4E
EMC filter	FS or FN series (optional; see Table 9.4)	
Low Voltage Directive	IEC/EN 61800-5-1: 2007	
EMC Directives	IEC/EN 61800-3: 2004	
Immunity	Second environment (Industrial)	
Emission	Category C2	Category C3

Note # Enclosure: M (IP21) or L (IP55).

9.2 Conformity to the Low Voltage Directive in the EU

To use IMO inverters as a product conforming to the Low Voltage Directive in the EU, refer to guidelines given on pages vi to viii.

9.3 Compliance with EMC Standards

9.3.1 General

The CE marking on inverters does not ensure that the entire equipment including our CE-marked products is compliant with the EMC Directive. Therefore, CE marking for the equipment shall be the responsibility of the equipment manufacturer. For this reason, IMO's CE mark is indicated under the condition that the product shall be used within equipment meeting all requirements for the relevant Directives. Instrumentation of such equipment shall be the responsibility of the equipment manufacturer.

Generally, machinery or equipment includes not only our products but other devices as well. Manufacturers, therefore, shall design the whole system to be compliant with the relevant Directives.



EMC certification testing is performed using the following wiring distances between the inverter and motor (shielded wire):

VXA2A5#-4E to VXA176#-4E:	75 m
VXA210S-4E to VXA1370S-4E (inverter alone):	10 m
VXA210S-4E to VXA1370S-4E (with filter):	20 m

9.3.2 Recommended installation procedure

To make the machinery or equipment fully compliant with the EMC Directive, have certified technicians wire the motor and inverter in strict accordance with the procedure given below.

- 1) Use shielded wires for the motor cable and route the cable as short as possible. Firmly clamp the shield to the specified point or the grounded metal plate inside the inverter. Further, connect the shielding layer electrically to the grounding terminal of the motor.
- 2) For the inverters of 11 to 90 kW, be sure to pass the main circuit power input lines of the inverter through a ferrite core in wiring.
 - For wiring of the main circuit power input lines, refer to Chapter 2, Section 2.2.1 "(4) Wiring the main circuit power input wires."
- 3) Connect the grounding wires to the grounding terminals without passing them through the ferrite core.

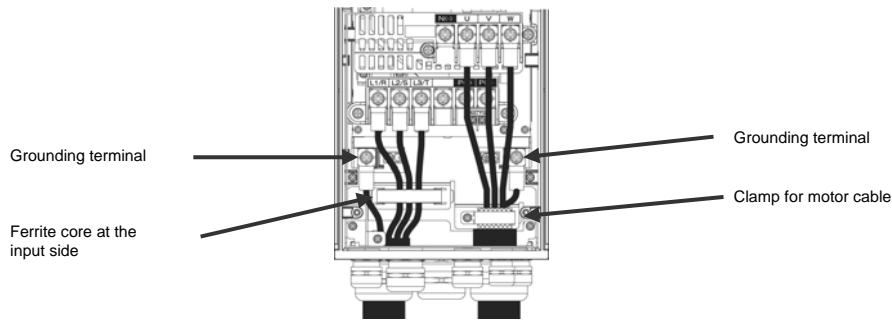

Figure 9.1 Wiring to Main Circuit Terminals for Inverters of 30/37 kW

- 4) For connection to inverter's control terminals and for connection of the RS-485 communication signal cable, use shielded wires. As with the motor, clamp the shields firmly to the specified point or the grounded metal plate inside the inverter.

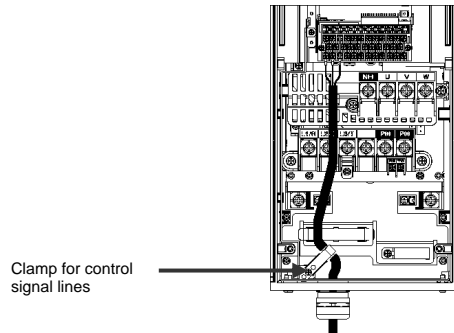

Figure 9.2 Wiring to Control Circuit Terminals for Inverters of 30/37 kW

- 5) When using an externally connected EMC filter (optional), place the inverter and filter on a grounded metal plate such as the surface of a panel, as shown in Figure 9.3. If noise emissions exceed the standard, place the inverter and any peripheral equipment inside a metal panel. For more information about how to use the inverter in combination with a filter, see Table 9.4.

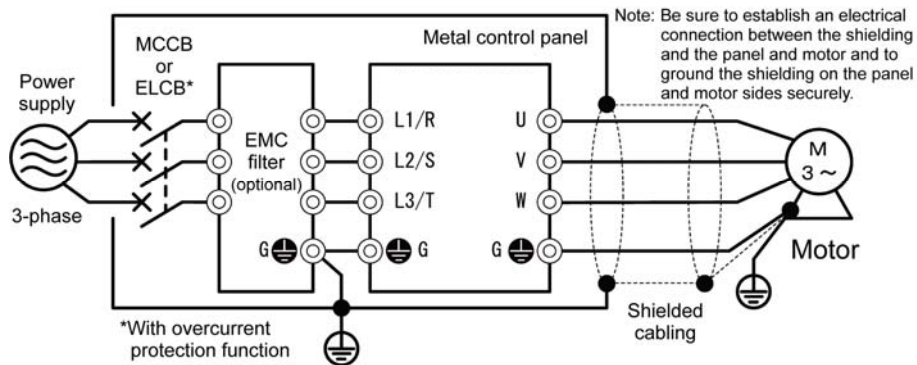

Figure 9.3 Installation inside a Panel

9.3.3 Leakage current of the EMC filter

This product uses grounding capacitors for noise suppression which increase the leakage current. Check whether there is no problem with electrical systems. When using an EMC filter, the leakage current listed in Table 9.4 is added. Before adding the filter, consider whether the additional leakage current is allowable in the context of the overall system design.

Table 9.3 Inverter Leakage Current

Input power	Inverter type	Leakage current (mA)	Input power	Inverter type	Leakage current (mA)
Three-phase 400 V	VXA2A5#-4E	55	Three-phase 400 V	VXA150#-4E	148
	VXA4A1#-4E			VXA176#-4E	
	VXA5A5#-4E			VXA210S-4E	
	VXA9#-4E			VXA253S-4E	3
	VXA13A5#-4E			VXA304S-4E	
	VXA18A5#-4E	VXA377S-4E			
	VXA24A5#-4E	VXA415S-4E			
	VXA32#-4E	VXA520S-4E			
	VXA39#-4E	VXA585S-4E			
	VXA45#-4E	VXA650S-4E			
	VXA60#-4E	VXA740S-4E			
	VXA75#-4E	VXA960S-4E			
	VXA91#-4E	VXA1170S-4E			
	VXA112#-4E	VXA1370S-4E			

* Calculated based on these measuring conditions: 400 V, 50 Hz, neutral grounding in Y-connection, interphase voltage unbalance ratio 2%.

Table 9.4 EMC Filter (Optional) Use and Leakage Currents

Input power	Inverter type	Filter model	EMC filter leakage current (mA)
Three-phase 400 V	VXA210S-4E	RF304A-4B	59
	VXA253S-4E		
	VXA304S-4E		
	VXA377S-4E	RF520A-4B	78
	VXA415S-4E		
	VXA520S-4E		
	VXA585S-4E	RF840A-4B	38
	VXA650S-4E		
	VXA740S-4E		
	VXA960S-4E	RF960A-4B	39
	VXA1170S-4E	RF1370A-4B	38
	VXA1370S-4E		

9.4 Harmonic Component Regulation in the EU

9.4.1 General comments

When general-purpose industrial inverters are used in the EU, the harmonics emitted from inverters to the power lines are strictly regulated as stated below.

If an inverter whose rated input is 1 kW or less is connected to the public low-voltage power supply, it is regulated by the harmonics emission regulation IEC/EN 61000-3-2. If an inverter whose input current is 16 A or above and 75 A or below is connected to the public low-voltage power supply, it is regulated by the harmonics emission regulation IEC/EN 61000-3-12.

Note that connection to the industrial low-voltage power lines is an exception. (See Figure 9.3.)

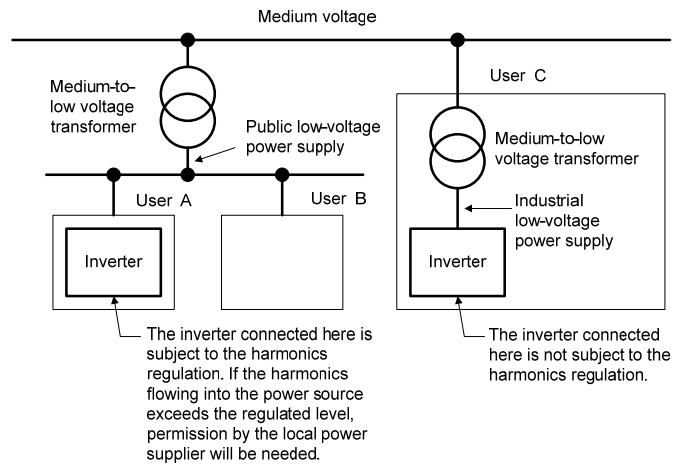

Figure 9.4 Power Source and Regulation

9.4.2 Compliance with IEC/EN 61000-3-2

The VXA2A5#-4E satisfies the IEC/EN 61000-3-2, so it can be connected to the public low-voltage power supply.

9.4.3 Compliance with IEC/EN 61000-3-12

To bring the VXA2A5#-4E to VXA75#-4E into compliance with the IEC/EN 61000-3-12, connect them to the power supply whose short-circuit ratio R_{sce} is 120 or above.

9.5 Compliance with UL Standards and Canadian Standards (cUL certification) Under application)

9.5.1 General

Originally, the UL standards were established by Underwriters Laboratories, Inc. as private criteria for inspections/investigations pertaining to fire/accident insurance in the USA. The UL marking on IMO products is related to the UL Standard UL508C.

cUL certification means that UL has given certification for products to clear CSA Standards. cUL certified products are equivalent to those compliant with CSA Standards. The cUL marking on IMO products is related to the CSA Standard C22.2 No. 14.

9.5.2 Considerations when using JAGUAR VXA in systems to be certified by UL and cUL

If you want to use the JAGUAR VXA series of inverters as a part of UL Standards or CSA Standards (cUL certified) certified product, refer to the related guidelines described on pages ix to xi.

PUMP Application Inverter.

Jaguar VXA

Instruction Manual

First Edition, Nov 2013

IMO Precision Controls Ltd

The purpose of this instruction manual is to provide accurate information in handling, setting up and operating of the JAGUAR VXA series of inverters. Please feel free to send your comments regarding any errors or omissions you may have found, or any suggestions you may have for generally improving the manual.

In no event will IMO Precision Controls Ltd. be liable for any direct or indirect damages resulting from the application of the information in this manual.

IMO Precision Controls Ltd.

1000 North Circular Road, Staples Corner, London, NW2 7JP England

Phone: +44 (0)20 8452 6444 Fax: +44 (0)20 8450 2274

URL <http://www.imopc.com>
